



**NOTICE OF A REGULAR MEETING TO BE HELD BY THE
McALLEN PUBLIC UTILITY BOARD OF TRUSTEES**

DATE: Tuesday, January 9, 2024

TIME: 4:00 P.M.

PLACE: McAllen City Hall
Commission Chambers – 3rd Floor
1300 Houston Avenue
McAllen, Texas 78501

SUBJECT MATTER:

See Subsequent Agenda.

CERTIFICATION

I, the Undersigned authority, do hereby certify that the attached agenda of meeting of the McAllen Public Utility Board of Trustees is a true and correct copy and that I posted a true and correct copy of said notice on the bulletin board in the Municipal Building, a place convenient and readily accessible to the general public at all times, and said Notice was posted on the 5th day of January, 2024 at 3:00 P.M. and will remain so posted continuously for at least 72 hours preceding the scheduled time of said meeting in accordance with Chapter 551 of the Texas Government Code.

A handwritten signature in blue ink, appearing to read "Clarissa Hernandez", is written over a horizontal line.

Clarissa Hernandez
Utility Board Secretary



**BOARD OF TRUSTEES MEETING
TUESDAY, JANUARY 9, 2024 – 4:00 PM
MCALLEN CITY HALL - 3RD FLOOR
1300 HOUSTON AVE, MCALLEN, TX 78501**

AGENDA

AT ANY TIME DURING THE COURSE OF THIS MEETING, THE MCALLEN PUBLIC UTILITY BOARD MAY RETIRE TO EXECUTIVE SESSION UNDER TEXAS GOVERNMENT CODE 551.071(2) TO CONFER WITH ITS LEGAL COUNSEL ON ANY SUBJECT MATTER ON THIS AGENDA IN WHICH THE DUTY OF THE ATTORNEY TO THE MCALLEN PUBLIC UTILITY BOARD UNDER THE TEXAS DISCIPLINARY RULES OF PROFESSIONAL CONDUCT OF THE STATE BAR OF TEXAS CLEARLY CONFLICTS WITH CHAPTER 551 OF THE TEXAS GOVERNMENT CODE. FURTHER, AT ANY TIME DURING THE COURSE OF THIS MEETING, THE MCALLEN PUBLIC UTILITY BOARD MAY RETIRE TO EXECUTIVE SESSION TO DELIBERATE ON ANY SUBJECT SLATED FOR DISCUSSION AT THIS MEETING, AS MAY BE PERMITTED UNDER ONE OR MORE OF THE EXCEPTIONS TO THE OPEN MEETINGS ACT SET FORTH IN TITLE 5, SUBTITLE A, CHAPTER 551, SUBCHAPTER D OF THE TEXAS GOVERNMENT CODE.

CALL TO ORDER

PLEDGE

INVOCATION

1. MINUTES:

- a) Approval of the Minutes for the Regular Meeting held December 12, 2023.

2. CONSENT AGENDA:

- a) Approval of Northgate Estates Subdivision
- b) Approval of MPU's 1st and Pecan Fire Hydrant Preliminary Reimbursement Certificate

3. BIDS AND CONTRACTS:

- a) Authorization to Purchase New Current Model MPU Vehicles through Cooperative Contract Pricing– Project No. 11-23-P20-133.

4. FUTURE AGENDA ITEMS

5. EXECUTIVE SESSION, CHAPTER 551, TEXAS GOVERNMENT CODE, SECTION 551.071 CONSULTATION WITH ATTORNEY, SECTION 551.072 LAND TRANSACTION, SECTION 551.074 PERSONNEL MATTERS; SECTION 551.087 ECONOMIC DEVELOPMENT NEGOTIATIONS

- a) Consultation with City Attorney regarding pending litigation (Section 551.071, T.G.C)

ADJOURNMENT

IF ANY ACCOMMODATION FOR A DISABILITY IS REQUIRED (OR INTERPRETERS FOR THE DEAF), NOTIFY UTILITY ADMINISTRATION (681-1630) FORTY-EIGHT (48) HOURS PRIOR TO THE MEETING DATE. WITH REGARD TO ANY ITEM, THE MCALLEN PUBLIC UTILITY BOARD OF TRUSTEES MAY TAKE VARIOUS ACTIONS; INCLUDING BUT NOT LIMITED TO RESCHEDULING AN ITEM IN ITS ENTIRETY FOR A FUTURE DATE OF TIME. THE MCALLEN PUBLIC UTILITY BOARD MAY ELECT TO GO INTO EXECUTIVE SESSION ON ANY ITEM WHETHER OR NOT SUCH ITEM IS POSTED AS AN EXECUTIVE SESSION ITEM AT ANY TIME DURING THE MEETING WHEN AUTHORIZED BY THE PROVISIONS OF THE OPEN MEETINGS ACT.

THE NEXT REGULARLY SCHEDULED BOARD MEETING WILL BE HELD ON JANUARY 23, 2024.



	AGENDA ITEM	<u>1.a.</u>
PUBLIC UTILITY BOARD	DATE SUBMITTED	12/19/2023
	MEETING DATE	1/9/2024

1. Agenda Item: Approval of the Minutes for the Regular Meeting held December 12, 2023.

2. Party Making Request:

3. Nature of Request:

4. Budgeted:

Bid Amount:	_____	Budgeted Amount:	_____
Under Budget:	_____	Over Budget:	_____
		Amount Remaining:	_____

5. Reimbursement:

6. Routing:
Savannah Arredondo Created/Initiated - 12/19/2023

7. Staff's Recommendation:

8. City Attorney: Approve. IJT

9. MPU General Manager: Approved - MAV

10. Director of Finance for Utilities: APPROVED - MSC

**STATE OF TEXAS
COUNTY OF HIDALGO
CITY OF MCALLEN**

The McAllen Public Utility Board (MPUB) convened in a Regular Meeting on **Tuesday, December 12, 2023**, at 4:00 pm at in the City Commission Chambers at City Hall with the following present:

	Charles Amos	Chairman
	Ernest Williams	Vice-Chairman
	Albert Cardenas	Trustee
Absent:	Javier Villalobos	Ex-Officio Member/Mayor
	Ricardo Godinez	Trustee
Staff:	Marco A. Vega, P.E.	General Manager
	Isaac Tawil	City Attorney
	J.J. Rodriguez	Assistant General Manager
	Clarissa Hernandez	Utility Board Secretary
	Savannah Arredondo	Assistant to the Utility Board Secretary
	Maria Chavero	Director of Finance for Utilities
	Pablo Rodriguez	Assistant Director for Customer Relations
	Carlos Gonzalez, P.E.	Utility Engineer
	Edward Gonzalez	Director of Water Systems
	David Garza	Director of Wastewater Systems
	Marco Ramirez, P.E.	Utility Engineer
	Patrick Gray	GIS Coordinator
	Juan Vallejo	Assistant Director of Water Systems
	Janet Landeros	Grants & Contracts Coordinator
	Joe Moreno	Water Plant Manager
	Valeria Rios	Treasury Accountant
	Christina Molano	Water Lab Manager
	Brittney Salinas	Assistant Manager
	Francisco Cardenas	Journey Mechanic II
	Jaime Garza	Pretreatment Inspector
	Yesenia Tijerina	Senior Administrative Clerk
	Andres Buitron	Administrative Clerk at Trans. & Dist
	Jorge Duron	Maintenance Worker at Trans. & Dist
	Miguel Castillo	Meter Reader
	Jocelyne Lopez	Customer Relations
	Rafael Leija	Water Plant Operator
	Jair Oropeza	Journey Mechanic II
	Mario Gauna	Wastewater Lift Station Operator
	Alejandra Martinez	Customer Relations
	Julio Oviedo	Wastewater Collections Manager

CALL TO ORDER:

Chairman Amos called the meeting to order at 4:02 p.m.

1. MINUTES:

- a) Approval of the Minutes for the Regular Meeting held November 28, 2023.

Trustee Cardenas moved to approve the minutes for the regular meeting held on November 28th, 2023. Vice-Chairman Williams seconded the motion. The motion carried unanimously by those present.

2. CONSENT AGENDA

Trustee Cardenas moved to approve items 2a through 2c. Vice-Chairman Williams seconded the motion. The motion carried unanimously by those present.

- a) Approval of Norlola Subdivision
b) Approval of Dos Lobos Ph.1 Subdivision
c) Approval of McAllen South Industrial Park Phase II Subdivision

3. ORDERS:

Vice-Chairman Williams moved to approve items 3a through 3e. Trustee Cardenas seconded the motion. The motion carried unanimously by those present.

- a) Order amending the budget of the McAllen Public Utility Board of Trustees for Fiscal Year 2023-2024 for an increase in expenditures within the Water Depreciation Fund.
b) Order amending the budget of the McAllen Public Utility Board of Trustees for Fiscal Year 2023-2024 for an increase in expenditures within the Water Capital Improvement Fund.
c) Order amending the budget of the McAllen Public Utility Board of Trustees for Fiscal Year 2023-2024 for an increase in expenditures within the Water Revenue Bond Fund.
d) Order amending the budget of the McAllen Public Utility Board of Trustees for Fiscal Year 2023-2024 for an increase in expenditures within the Wastewater Depreciation Fund.
e) Order amending the budget of the McAllen Public Utility Board of Trustees for Fiscal Year 2023-2024 for an increase in expenditures within the Wastewater Capital Improvement Fund.

4. MANAGER'S REPORT:

- a) Consideration and Possible action to write-off the 3rd Quarter Bad Debt Fiscal Year 2022-2023.

Trustee Cardenas moved to approve the write-off of the 3rd Quarter Bad Debt Fiscal Year 2022-2023. Vice-Chairman Williams Seconded the motion. The motion carried unanimously by those present.

- b) Reimbursement Collections Update as of September 30, 2023.

Janet Landeros, Grants and Contracts Coordinator presented the Reimbursement updates for collections for the 4th quarter of fiscal year 2023 from July 1st to September 30th, 2023, for informational purposes only. The water reimbursements that were collected during the 4th quarter total \$62,602.18 and administrative fees for \$10,872.36 for a total of \$73,474.54. The wastewater reimbursements collected during this quarter total \$51,905.44 and the fees associated were \$10,057.25 for a total of \$61,962.69. The total collected in the 4th quarter is \$135,437.23. The total collected during Fiscal Year 2022-2023, which is from October 1, 2022, through September 30, 2023, is \$306,360.93. Included in this is \$160,960.53 for water and \$143,237.65 for wastewater. The Sharyland buyout was \$2,162.75.

5. FUTURE AGENDA ITEMS

Mr. Marco Vega, P.E., General Manager stated the Board Retreat should be the last week of February 2024 or the first week of March 2024.

6. EXECUTIVE SESSION, CHAPTER 551, TEXAS GOVERNMENT CODE, SECTION 551.071 CONSULTATION WITH ATTORNEY, SECTION 551.072 LAND TRANSACTION, SECTION 551.074 PERSONNEL MATTERS; SECTION 551.087 ECONOMIC DEVELOPMENT NEGOTIATIONS

Chairman Amos recessed the meeting at 4:10 p.m. to go into Executive Session. Chairman Amos reconvened the meeting at 4:34 p.m.

- a) Consultation with City Attorney regarding pending litigation (Section 551.071, T.G.C)

No action was taken.

- b) Discussion and possible lease, sale, or purchase of real estate property: Tract 1 (Section 551.072, T.G.C)

Isaac Tawil, City Attorney, stated his recommendation is for the board to consider a motion authorizing the General Manager and City Attorney to negotiate the lease, sale, or purchase of real estate property described in

executive session and to negotiate and execute any and all documents to further the same.

Trustee Cardenas moved to approve item 6b on City Attorneys recommendations. Vice-Chairman seconded the motion. The motion carried unanimously by those present.

ADJOURNMENT

There being no other business to come before the Board, the meeting was unanimously adjourned at 4:44 p.m.

Charles Amos, Chairman

Attest:

Clarissa Hernandez
Utility Board Secretary



	AGENDA ITEM	<u>2.a.</u>
PUBLIC UTILITY BOARD	DATE SUBMITTED	12/29/2023
	MEETING DATE	1/9/2024

1. Agenda Item: Approval of Northgate Estates Subdivision
2. Party Making Request:
Marco Ramirez, Utility Engineer P.E.
3. Nature of Request: Consideration and approval of the Northgate Estates Subdivision.
4. Budgeted:

Bid Amount:	_____	Budgeted Amount:	_____
Under Budget:	_____	Over Budget:	_____
		Amount Remaining:	_____
5. Reimbursement:
6. Routing:
Patrick Gray Created/Initiated - 12/29/2023
7. Staff's Recommendation: Staff is recommending Board approval of the Northgate Estates Subdivision.
8. City Attorney: Approve. IJT
9. MPU General Manager: Approved - MAV
10. Director of Finance for Utilities: Approved - MSC

Memo

TO: Marco A. Vega, P.E., General Manager
J.J. Rodriguez, Asst. General Manager

THRU: Carlos Gonzalez, P.E., Utility Engineer
Marco Ramirez, P.E., Utility Engineer

FROM: Patrick R. Gray, E.I.T., GIS Coordinator

DATE: January 9, 2024

SUBJECT: **Consideration & Approval of Northgate Estates Subdivision**

This property is located on the north side of Northgate Ln. approximately 750 linear feet and adjacent to La Floresta Subdivision. It is located within the McAllen City Limits and is being proposed as R-1 Residential. The tract consists of 8.876 acres and will have 13 single-family home lots.

The subdivision application was originally filed with the City on April 13, 2023 and has received preliminary P&Z approval on October 3, 2023. The information required from the developer's engineer for this agenda was received on December 28, 2023.

Utility plan/availability is described as follows:

1. **Water Service:** The developer is proposing to service the subdivision with an 8" waterline that will be tying into two (2) connections left prepped from the La Floresta Subdivision. The developer has the intension to connect and loop the system using these two (2) connections. The developer is also proposing to install three (3) fire hydrants to serve as fire protection.
2. **Sewer Service:** The developer is proposing to service the subdivision with an 8" sanitary sewer line that fill flow into a sewer clean out left prepped and available from the La Floresta Subdivision on N. 18th St.
3. This property falls within the MPU Northgate Water Bond reimbursement service area.

Staff recommends MPUB approval of the subdivision application as proposed subject to the following:

- 1.) **Dedication of a utility easement, possibly along the perimeter of the property.**
- 2.) **Installation of the proposed public utility infrastructure to be constructed as proposed.**
- 3.) **Payment of a Waterline Reimbursement to MPU in the amount of \$10,919.41 for the Northgate Waterline Bond Project.**

Staff will be available for further discussion/questions at the MPUB meeting.

Thank you

TURBO

ENGINEERS, PLLC

Engineering Firm Reg # 21737
4013 Zion Ave McAllen, TX 78501
Phone: (956) 598-2940 roberto@turboengineers.net

UTILITY NARRATIVE

Northgate Estates Subdivision:

A 8.876 Acre [386,628.48 sqft.] tract of land, being parts or portions of lots 32 and 33, ebony heights citrus groves unit no. 2, Hidalgo County, Texas according to the plat or map thereof recorded in volume 6, page 44, map records of Hidalgo County, Texas.

Water Supply: Description:

Northgate Estates Subdivision is provided with potable water by the City of McAllen Public Utility Board. The City of McAllen Public Utility Board has eight (8) inch diameter waterlines running along N 20th and N 18th Steet terminating within the ROW of the Future Hobbs Drive.

The Water system for Northgate Estates Subdivision consists of lopping a proposed 8 in waterline within the Northgate Estates Subdivision, and connecting the proposed loop to the existing 8 in waterlines on N 20th and N 18th Steet within the ROW of Hobbs Drive. Fourteen (14) water service connections and 3 fire Hydrant Assemblies will be connected to the proposed 8 in waterline loop.

Sewage Facilities: Description:

Northgate Estates will be served by a sanitary sewer collection system running along the south ROW of Ozark Avenue owned by the City of McAllen Public Utility Board.

The proposed sanitary collection system for Northgate Estates consists of an 8 inch sanitary sewer line that runs east within the proposed ROW of Northgate Estates for 675ft, then turns north within a proposed utility easement for 200ft, then turns east within the ROW of Hobbs Drive for 118ft, then turns north re-laying the existing 8 inch pipe along N 18th Street and terminating at the existing manhole located at the southwest corner of the intersection of N 18th Street and Ozark Avenue.

Certification:

By my signature below, I certify that the water and sewage service facilities described above are in compliance with the model rules adopted under section 16.343, water code. I certify that the estimated costs to install water and sanitary sewer collection facilities, discussed above, are as follows:

Water Facilities – these facilities are to be constructed before final approval of the subdivision and have an anticipated cost of \$215,757.50.

Sanitary Sewer Collection facilities – these facilities are to be constructed before final approval of the subdivision and have an anticipated cost of \$154,540.00.

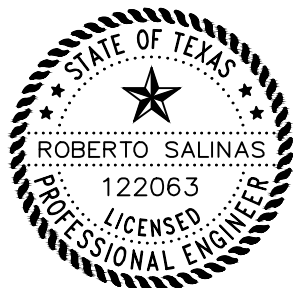

A handwritten signature in black ink that reads "Roberto Salinas, P.E.".

12/27/23

Roberto Salinas, P.E.
Texas Professional Engineer No. 122063
TBPELS Firm No. 21737

**SUBDIVISION REIMBURSEMENT WORKSHEET
NORTHGATE ESTATES SUBDIVISION**

WATER LINE REIMB. CALCULATIONS

WATER:	MPU: NORTHGATE WATER BOND PROJECT		
COST:	\$1,118.38 x	8.876 AC	\$9,926.74
10% ADMIN FEE <10 YEARS			992.67
WATER LINE REIMBURSEMENT			\$10,919.41

TOTAL REIMBURSEMENT DUE

\$10,919.41

Prepared By: RB Date: 12/4/23 Reviewed By: RB

Escrows will be adjusted upon execution of Final Reimbursement Certificate

I hereby agree to pay amounts indicated above and any additional costs determined in the Final Reimbursement Certificate as approved by McAllen Public Utility Board.

Signature: 

Print: MARCO LOPEZ

REIMBURSEMENT WAIVER

STATE OF TEXAS X

COUNTY OF HIDALGO X

THIS CERTIFICATE, issued by the McAllen Public Utility (MPUB), as authorized by such Board of Trustees, hereinafter called the MPUB to Urban City Developers, LLC hereinafter called the DEVELOPER.

1. The DEVELOPER is the developer of the following described property:

Northgate Estates Subdivision and proposes to construct Utility Improvements as shown on a plan
(Subdivision Name)

designed by Turbo Engineers, PLLC dated 12/4/2023, hereinafter called the
(Engineering Firm)

IMPROVEMENTS, as approved by the McAllen Public Utility Board on _____.
(Approval date)

2. By the execution of this certificate, the Developer hereby waives and disclaims the right to obtain reimbursement from Intervening Developers in accordance with the MPUB's Reimbursement Policy.

ISSUED in triplicate originals this _____ day of _____, 201_.

CITY OF McALLEN BY THE
McALLEN PUBLIC UTILITY

BY: _____
Mark Vega, P.E.
General Manager, McAllen Public Utility
Post Office Box 220
McAllen, Texas 78505-0220
(956) 681-1630

ATTEST:

Board Secretary

DEVELOPER

BY: 
Address: 601 PECAN, SUITE 180,
 McAllen, TX
 78501

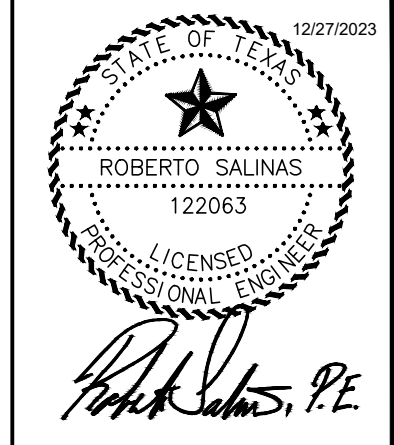
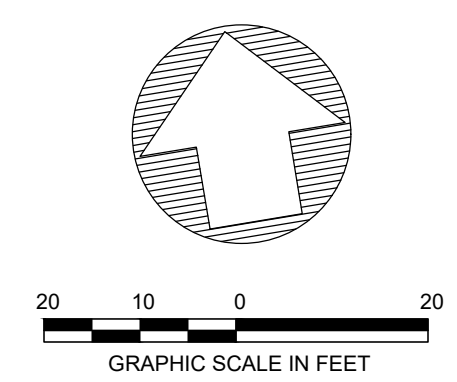
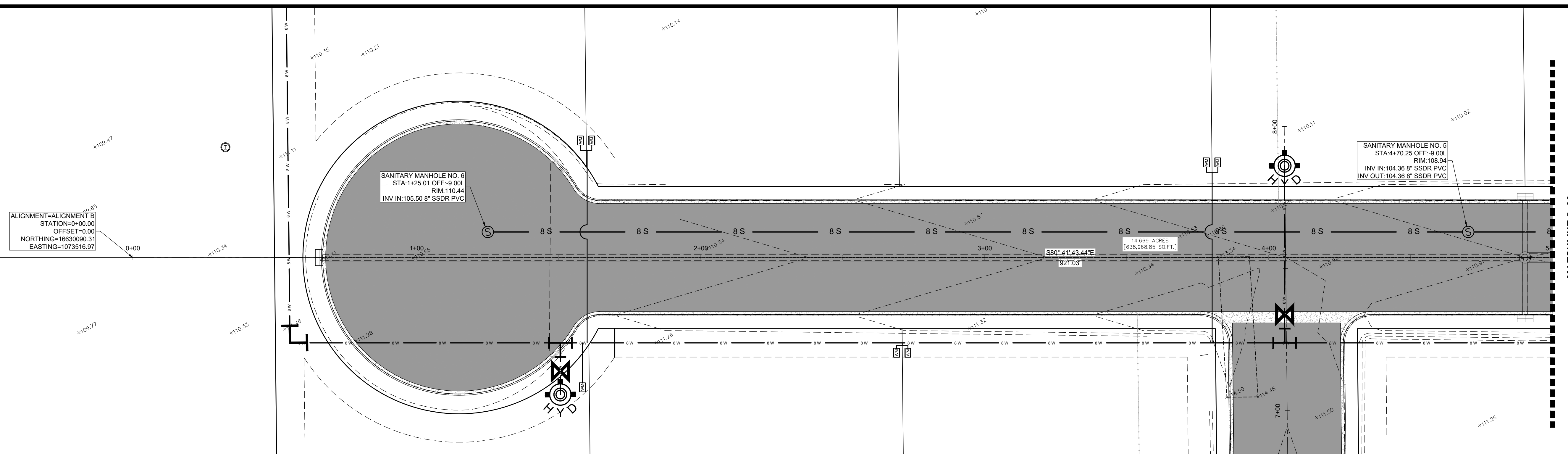

1203 ERIE AVE SUITE F
McALLEN, TX 78501
956.598.2940
roberto@turboengineers.net

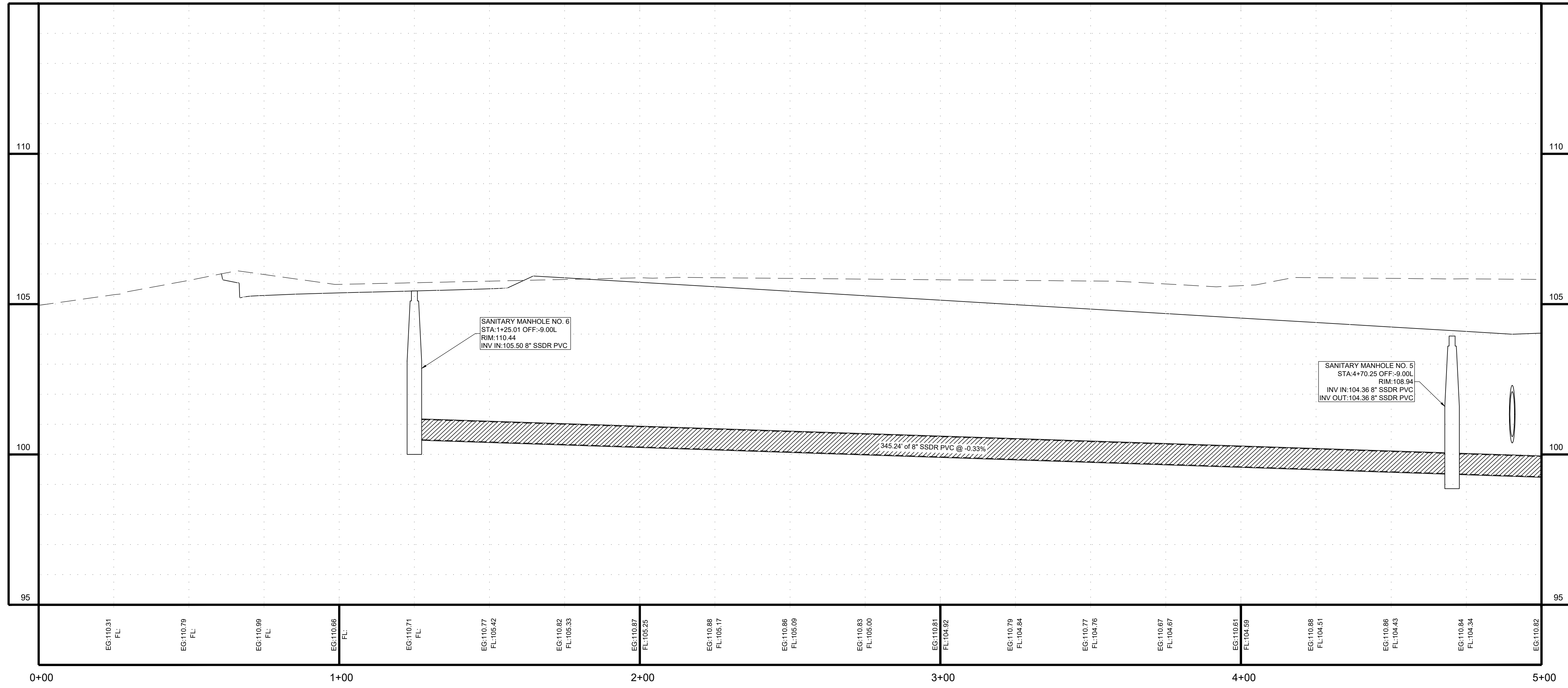
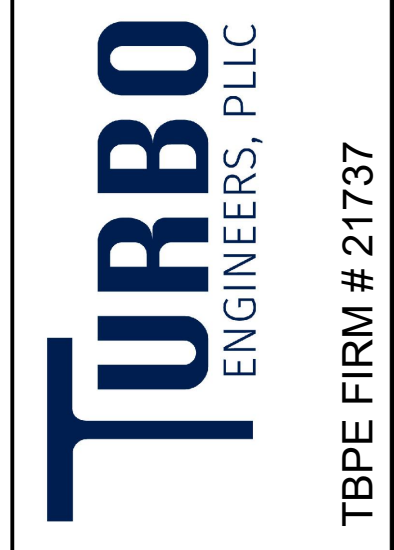

NORTHGATE ESTATES
McALLEN, TX 78504

REVISIONS

NO.	DATE	DESCRIPTION

WASTEWATER
PLAN AND
PROFILE

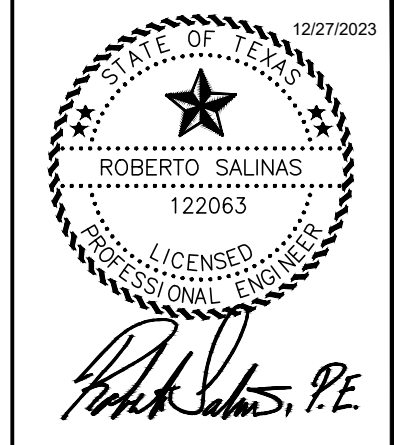
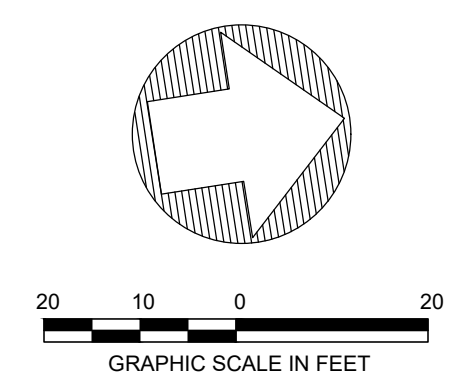
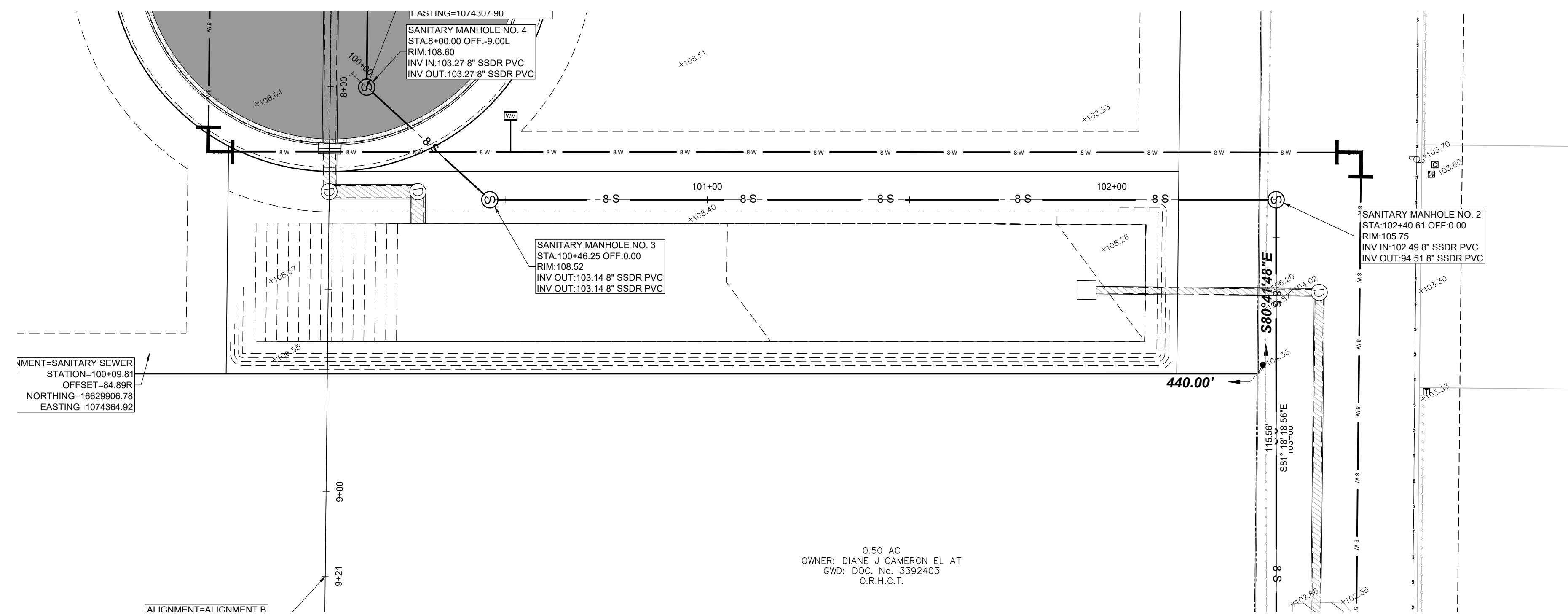

1203 ERIE AVE, SUITE F
McALLEN, TX 78501
956.598.2940
roberto@turboengineers.net

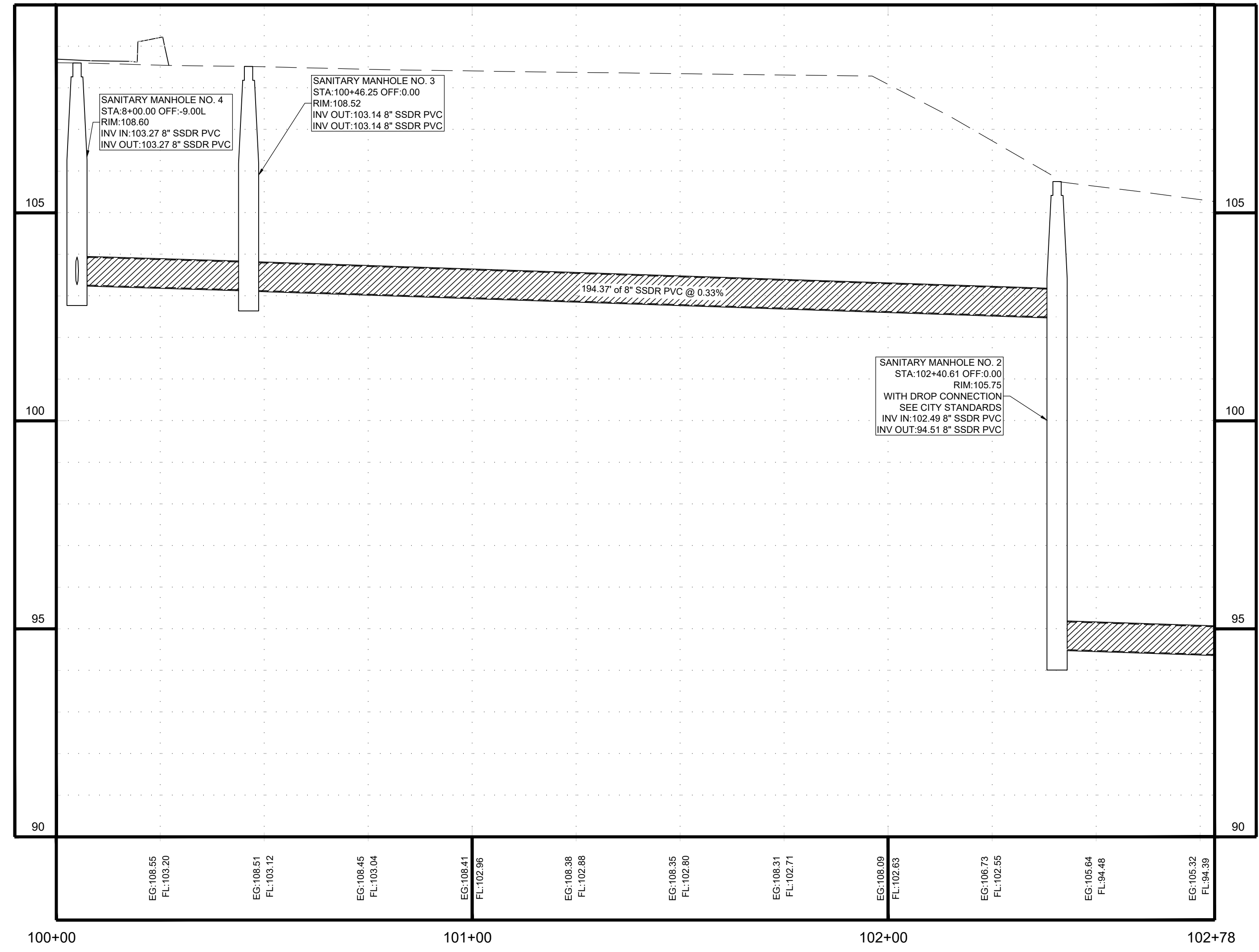
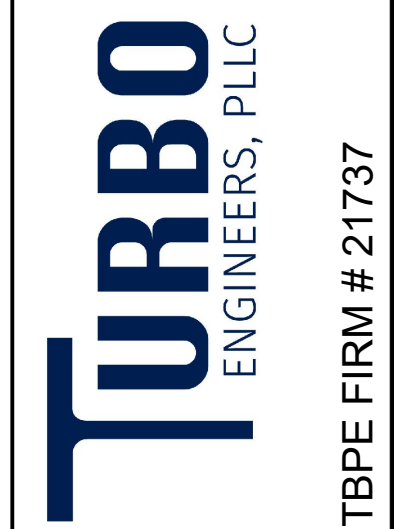

NORTHGATE ESTATES
McALLEN, TX 78504

REVISIONS

NO.	DATE	DESCRIPTION

WASTEWATER
PLAN AND
PROFILE

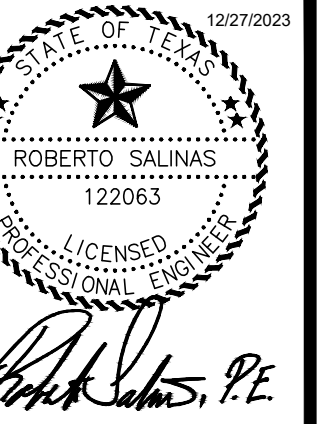

1203 ERIE AVE SUITE F
 McALLEN, TX 78501
 956.598.2940
 roberto@turboengineers.net

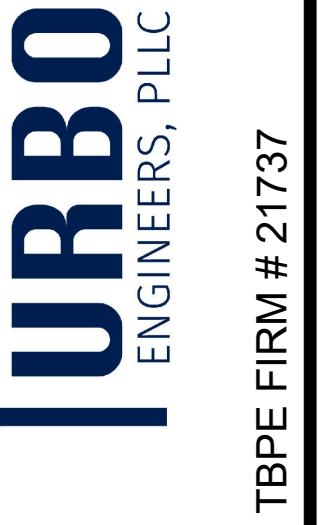

TBPE FIRM # 21737

NORTHGATE ESTATES
 McALLEN, TX 78504

REVISIONS

NO.	DATE	DESCRIPTION

WASTEWATER
 PLAN AND
 PROFILE

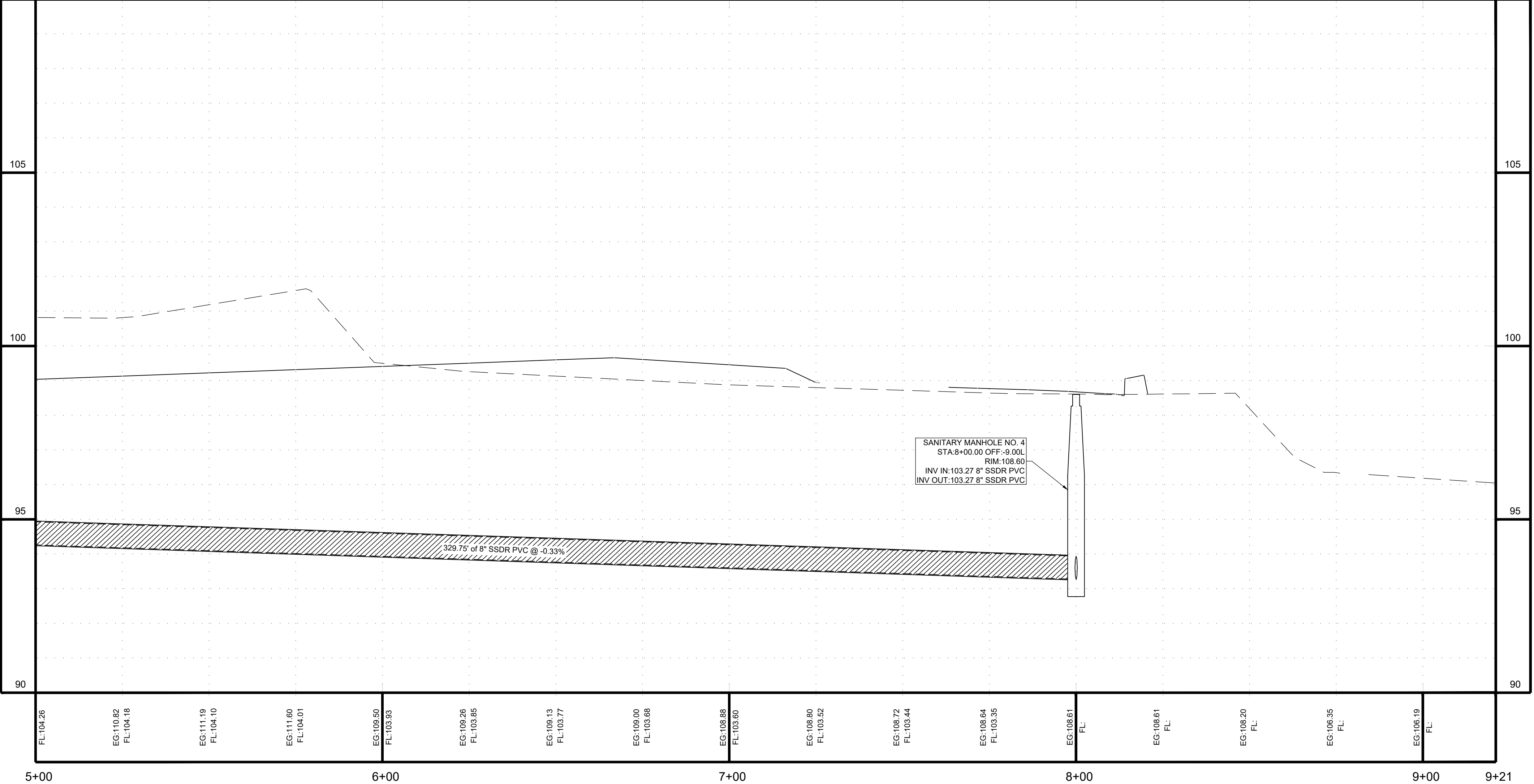
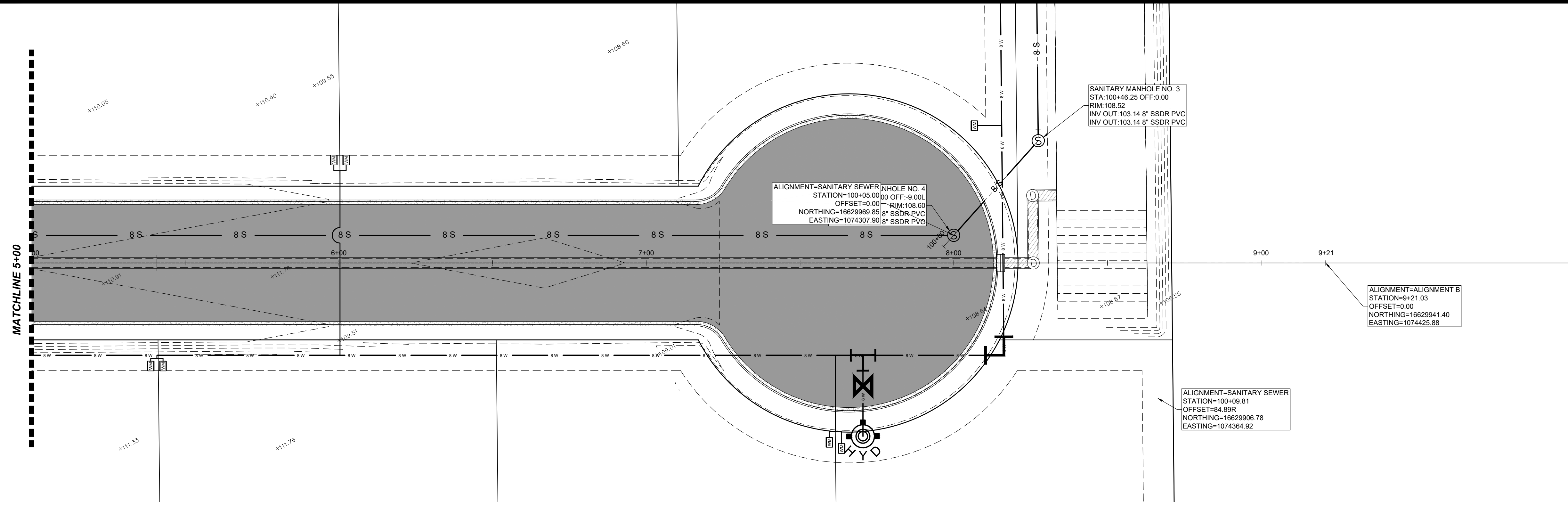
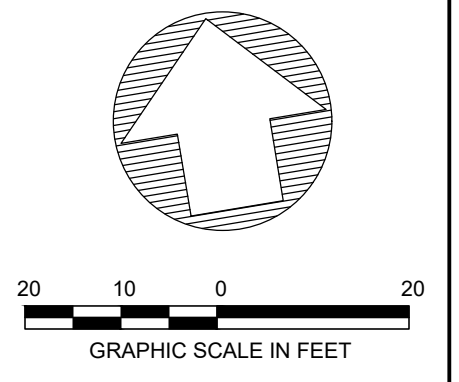

FL:104.28	EG:110.82 FL:104.18	EG:111.19 FL:104.10	EG:111.60 FL:104.01	EG:109.50 FL:103.63	EG:109.26 FL:103.85	EG:109.13 FL:103.77	EG:109.00 FL:103.66	EG:108.88 FL:103.60	EG:108.80 FL:103.52	EG:108.72 FL:103.44	EG:108.64 FL:103.35	EG:108.61 FL:	EG:108.61 FL:	EG:108.20 FL:	EG:108.35 FL:	EG:108.19 FL:	
5+00				6+00				7+00				8+00				9+00	9+21

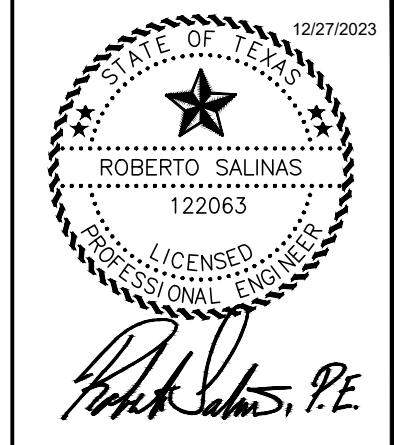
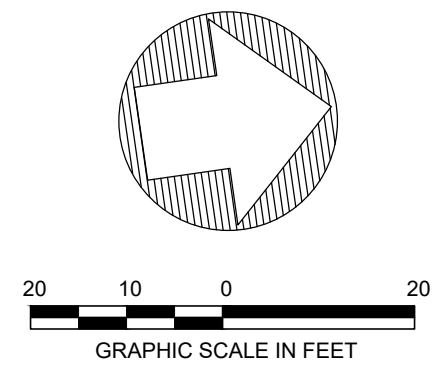
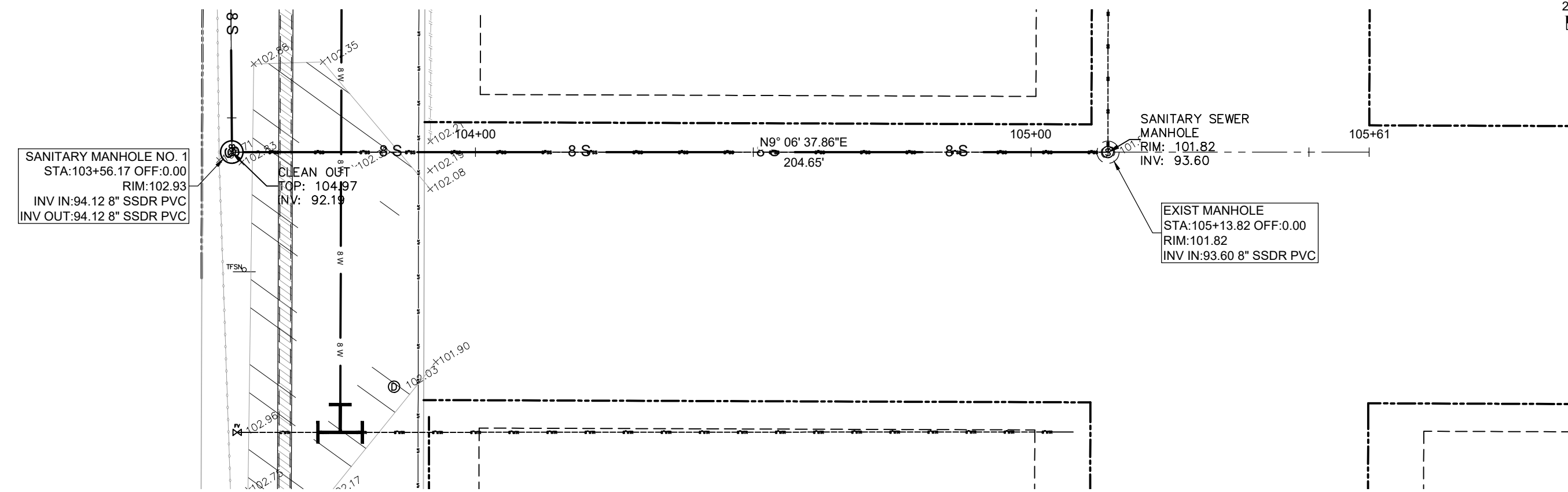
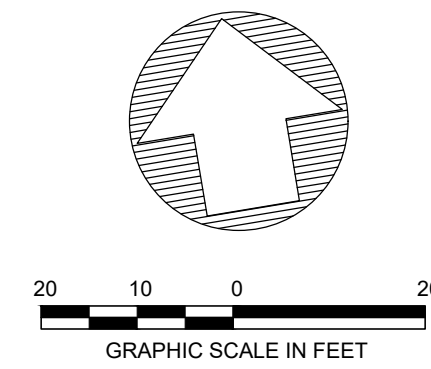
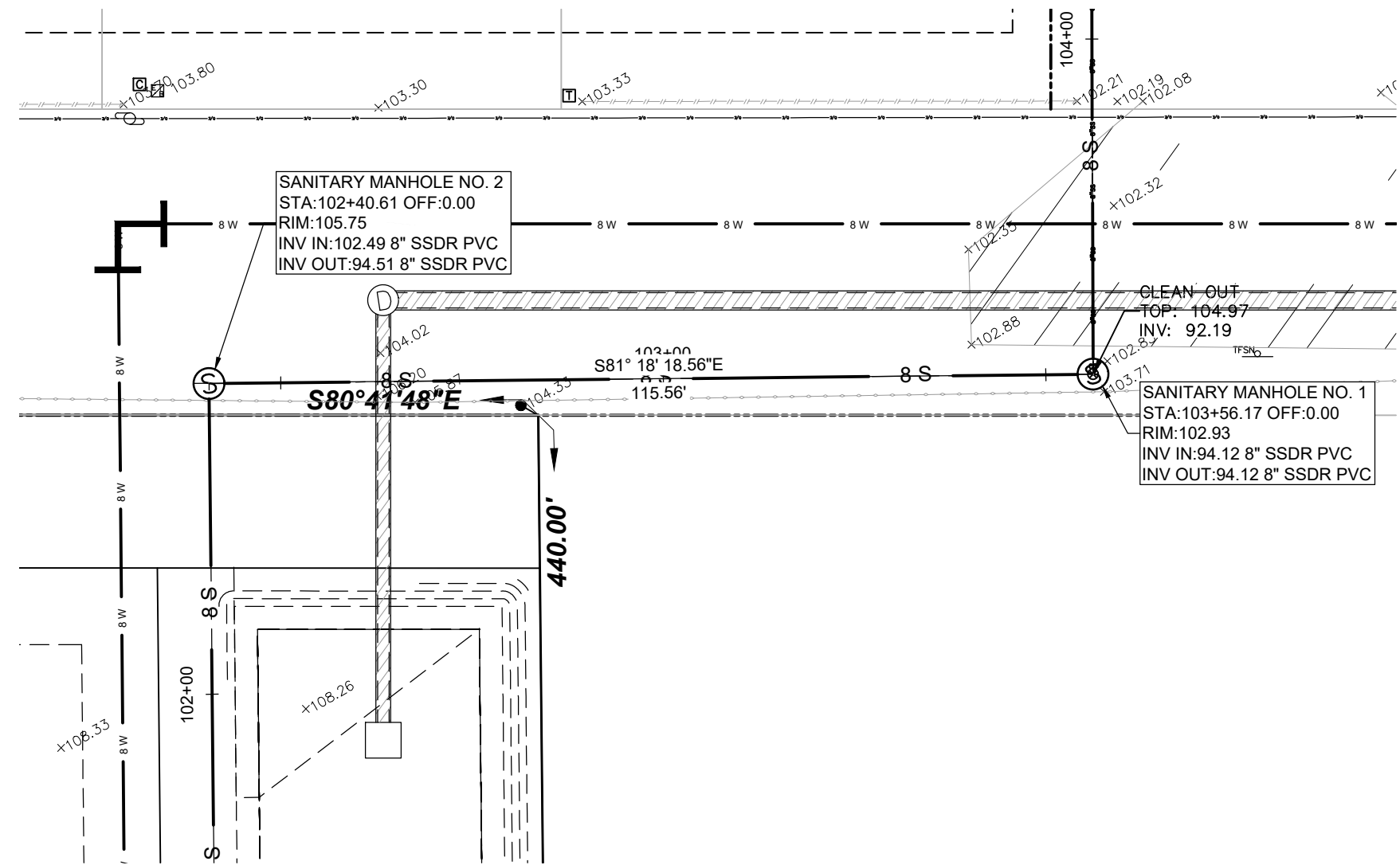

1203 ERIE AVE SUITE F
McALLEN, TX 78501
956.598.2940
roberto@turboengineers.net

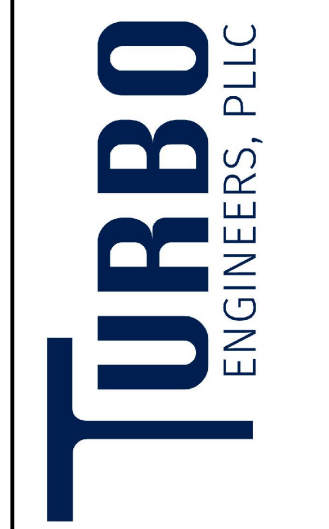

TBPE FIRM # 21737

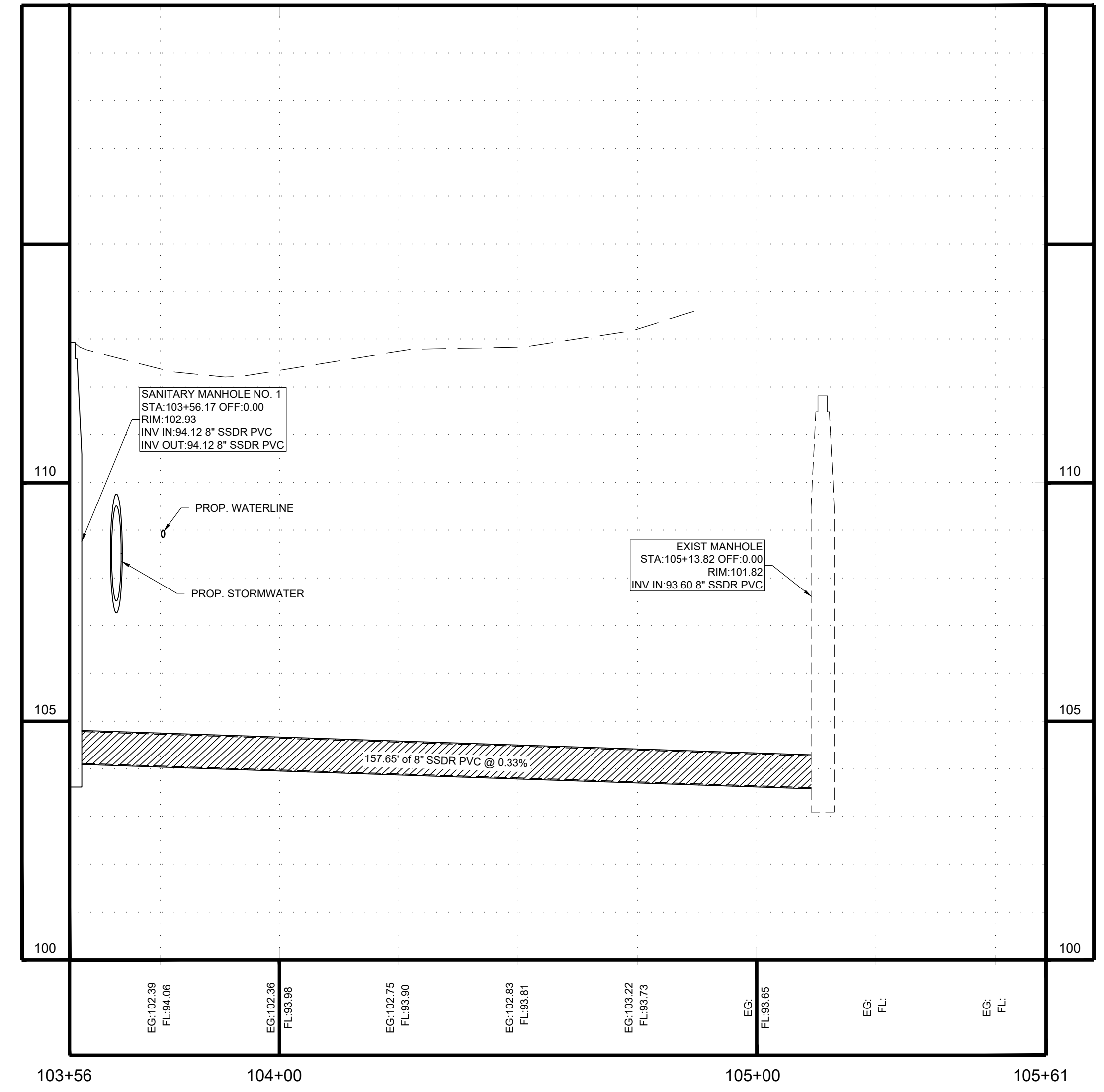
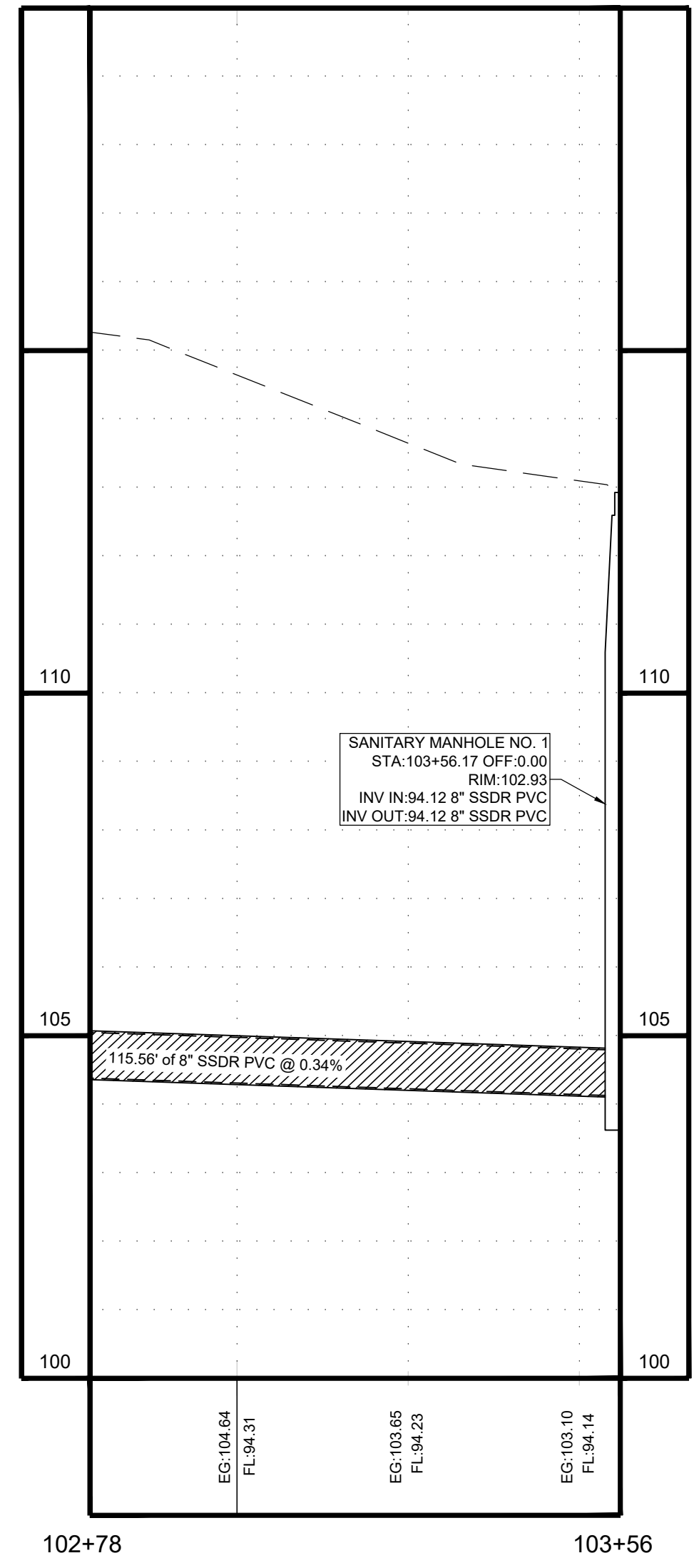

NORTHGATE ESTATES

McALLEN, TX 78504

REVISIONS

WASTEWATER PLAN AND PROFILE

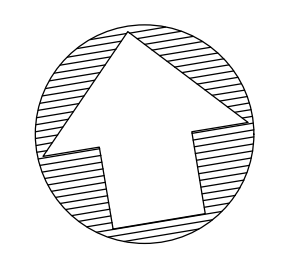
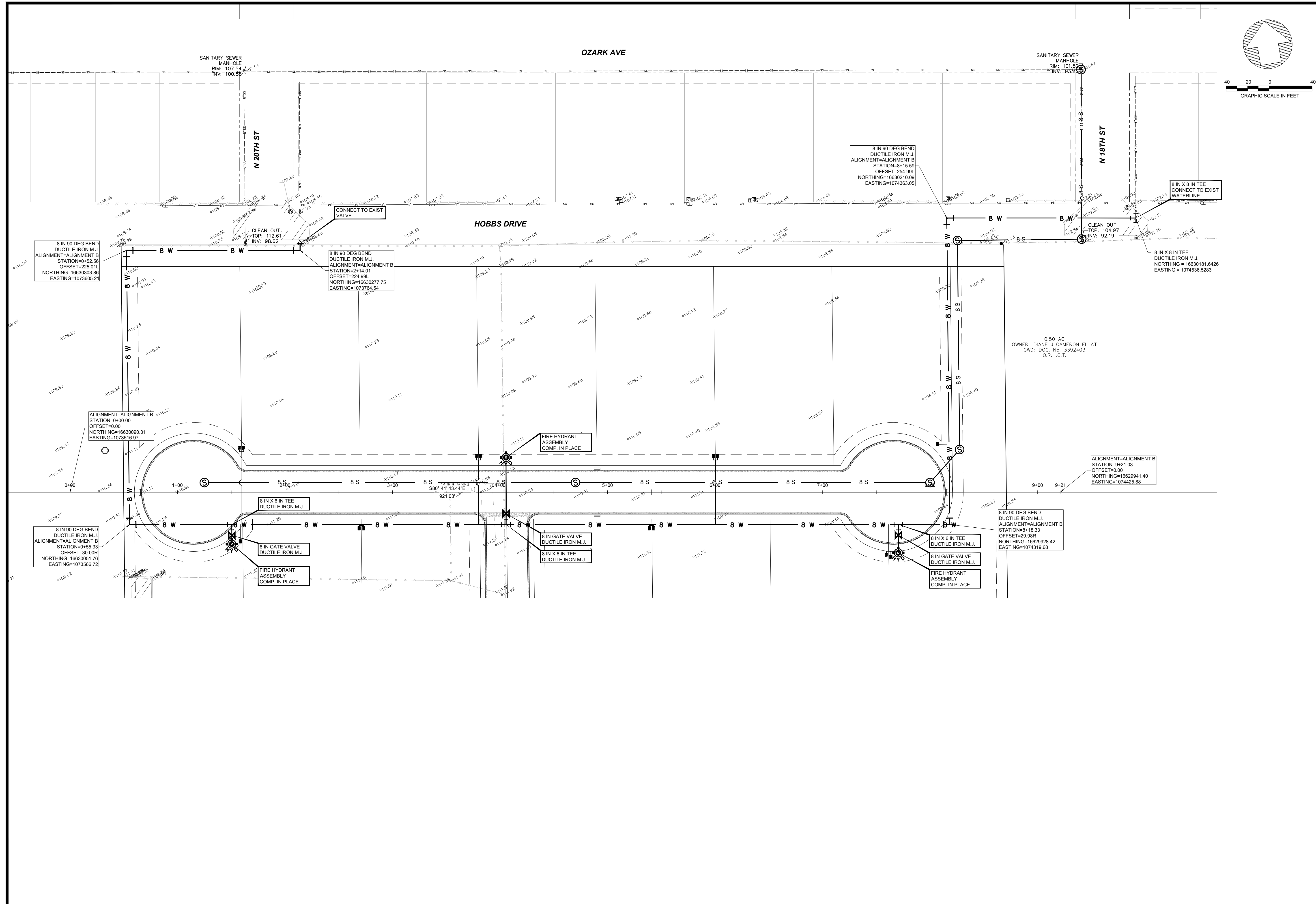

40 20 0 40
GRAPHIC SCALE IN FEET

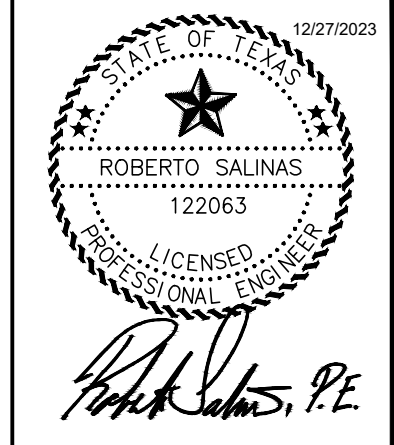

1203 ERIE AVE SUITE F
McALLEN, TX 78501
956.598.2940
roberto@turboengineers.net

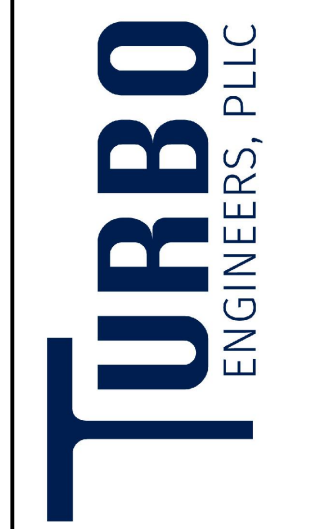

TBPE FIRM # 21737

NORTHGATE ESTATES

McALLEN, TX 78504

REVISIONS

PROP. WATER

MAP OF NORTHGATE ESTATES (PRIVATE SUBDIVISION)

A 8.876 ACRE [386,628.48 SQ.FT.] TRACT OF LAND, BEING PARTS OR PORTIONS OF LOTS 32 AND 33, EBONY HEIGHTS CITRUS GROVES UNIT NO. 2, HIDALGO COUNTY, TEXAS, ACCORDING TO THE PLAT OR MAP THEREOF RECORDED IN VOLUME 6, PAGE 44, MAP RECORDS OF HIDALGO COUNTY, TEXAS.

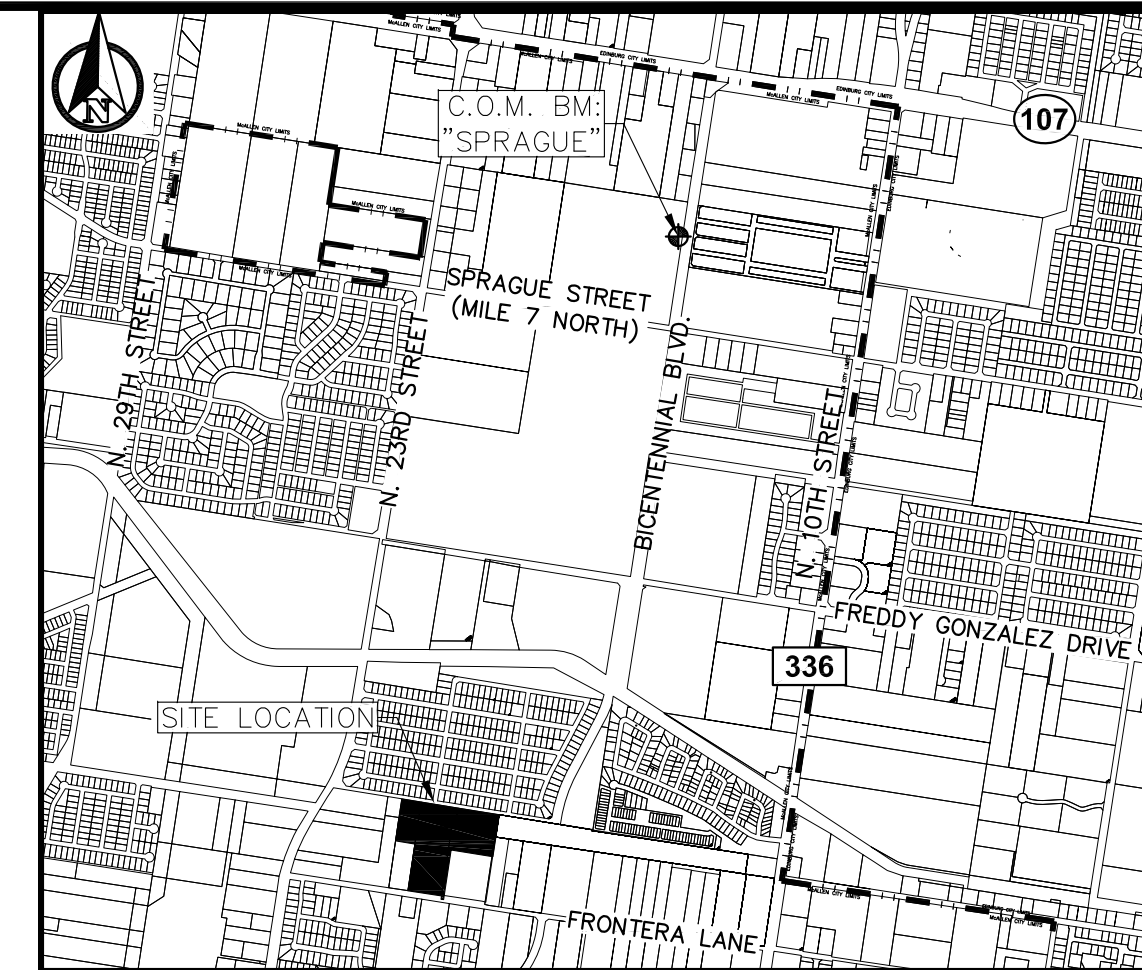

LOCATION MAP 1" = 2,000'

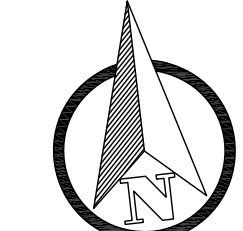
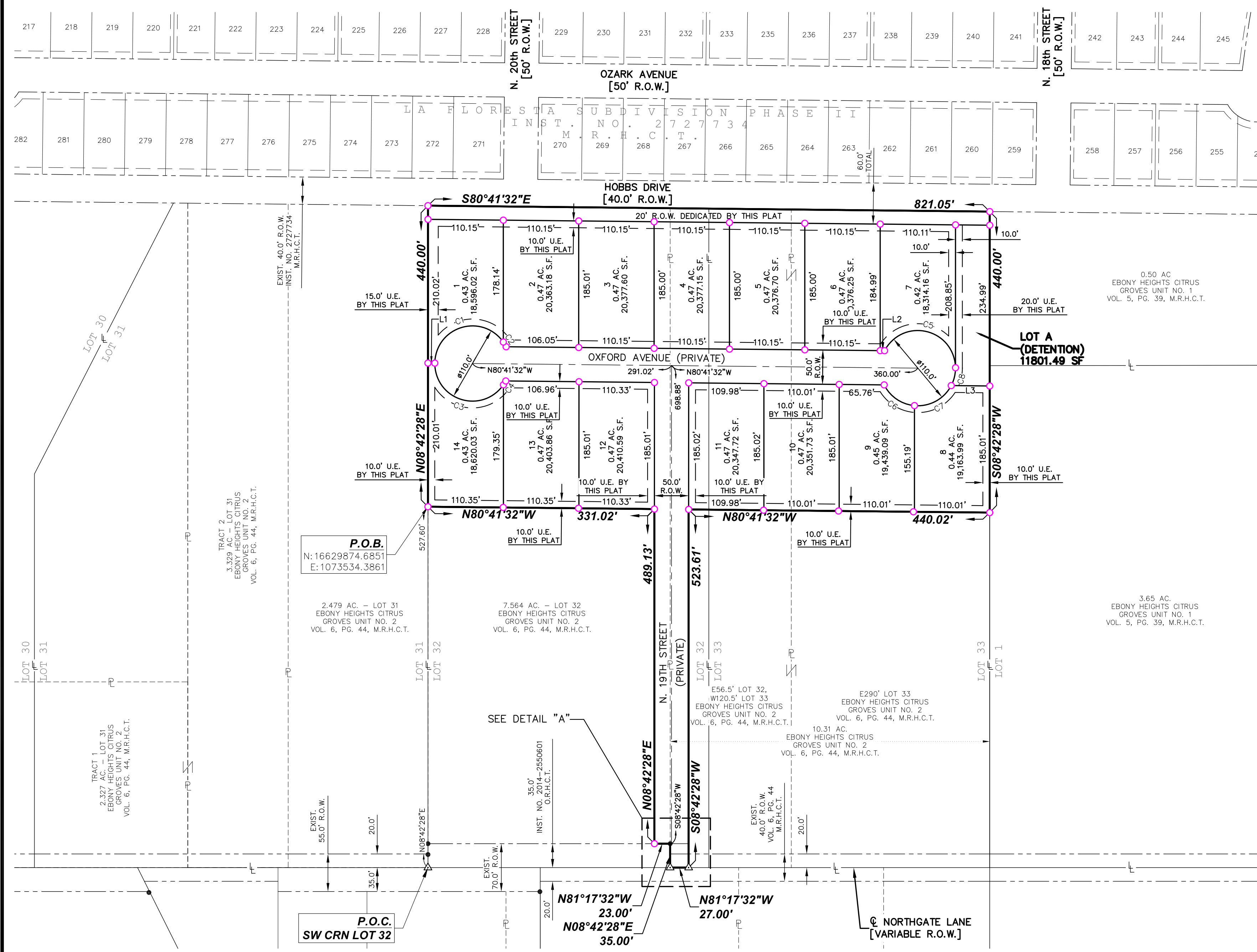

BASIS OF BEARINGS: TEXAS STATE PLANE COORDINATE SYSTEM SOUTH ZONE 4205
GRAPHIC SCALE IN FEET: 1"=100'

LEGEND

- BOUNDARY LINE
- - - RIGHT OF WAY LINE
- - - EASEMENT LINE
- LOT LINE
- - - PROPERTY LINE
- - - CONTOUR LINE WITH ELEVATION
- FOUND 1/2" IRON ROD OR AS NOTED
- FOUND 1/2" IRON PIPE
- SET 1/2" IRON ROD W/PINK CAP STAMPED "CLS RPLS #6388"
- △ CALCULATED POINT
- △ R.O.W. - RIGHT OF WAY
- △ VOL. - VOLUME
- △ PG. - PAGE
- △ DOC. - DOCUMENT
- △ EMT. - EASEMENT
- △ UTIL. - UTILITY
- △ POB - POINT OF BEGINNING
- △ NW - NORTHWEST
- △ SW - SOUTHWEST
- △ CNR. - CORNER
- △ GWD. - GENERAL WARRANTY DEED
- △ WD. - WARRANTY DEED
- △ SWD. - SPECIAL WARRANTY DEED
- △ WDL. - WARRANTY DEED W/VENDOR'S LIEN
- △ DT. - DEED OF TRUST
- △ WDFCL. - WARRANTY DEED IN LIEU OF FORECLOSURE
- △ SWDL. - SPECIAL WARRANTY DEED W/VENDOR'S LIEN
- △ O.R.H.C.T. - OFFICIAL RECORDS HIDALGO COUNTY TEXAS
- △ M.R.H.C.T. - MAP RECORDS HIDALGO COUNTY TEXAS
- △ D.R.H.C.T. - DEED RECORDS HIDALGO COUNTY TEXAS
- △ H.C.I.D. - HIDALGO COUNTY IRRIGATION DISTRICT
- △ - SAME OWNER

LINE #	LENGTH	DIRECTION
L1	10.00	N80°41'43"W
L2	6.38	N80°41'43"W
L3	56.27	N80°41'43"W

CURVE #	LENGTH	RADIUS	DELTA	CHORD DIRECTION	CHORD LENGTH
C1	138.79	55.00'	144°34'50"	S81°35'42"W	104.79'
C2	8.05'	55.00'	008°23'01"	N21°55'23"W	8.04'
C3	140.27'	55.00'	146°07'24"	S63°45'26"E	105.23'
C4	6.57'	55.00'	006°50'27"	N39°45'39"E	6.56'
C5	145.70'	55.00'	151°46'36"	N67°46'17"W	106.68'
C6	56.00'	55.00'	058°20'19"	S46°54'02"E	53.61'
C7	64.88'	55.00'	067°35'24"	N70°08'07"E	61.18'
C8	25.95'	55.00'	027°02'08"	N22°49'21"E	25.71'

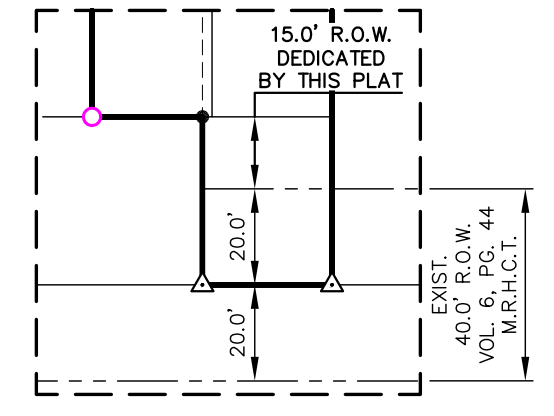

DETAIL "A" SCALE: 1"=40'

CERTIFICATE OF APPROVAL PLANNING & ZONING COMMISSION

I, THE UNDERSIGNED, CHAIRMAN OF THE PLANNING AND ZONING COMMISSION OF THE CITY OF McALLEN HEREBY CERTIFY THAT THIS SUBDIVISION PLAT CONFORMS TO ALL REQUIREMENTS OF THE SUBDIVISION REGULATIONS OF THIS CITY WHEREIN MY APPROVAL IS REQUIRED.

CHAIRMAN, PLANNING AND ZONING COMMISSION DATE

CITY OF McALLEN MAYOR CERTIFICATION

I, THE UNDERSIGNED, MAYOR OF THE CITY OF McALLEN, HEREBY CERTIFY THAT THIS SUBDIVISION PLAT CONFORMS TO ALL REQUIREMENTS OF THE SUBDIVISION REGULATIONS OF THIS CITY WHEREIN MY APPROVAL IS REQUIRED.

MAYOR, CITY OF McALLEN DATE

CITY SECRETARY DATE

CERTIFICATE OF APPROVAL HIDALGO COUNTY DRAINAGE DISTRICT No. 1

HIDALGO COUNTY DRAINAGE DISTRICT NO. 1 HEREBY CERTIFIES THAT THE DRAINAGE PLANS FOR THIS SUBDIVISION COMPLY WITH THE MINIMUM STANDARDS OF THE DISTRICT ADOPTED UNDER TEXAS WATER CODE NO. 49.21(C). THE DISTRICT HAS NOT REVIEWED AND DOES NOT CERTIFY THAT THE DRAINAGE STRUCTURES DESCRIBED ARE APPROPRIATE FOR THE SPECIFIC SUBDIVISION, BASED ON GENERALLY ACCEPTED ENGINEERING CRITERIA. IT IS THE RESPONSIBILITY OF THE DEVELOPER OF THE SUBDIVISION AND ITS ENGINEER TO MAKE THESE DETERMINATIONS.

RAUL E. SESIN, P.E., C.F.M. GENERAL MANAGER DATE

STATE OF TEXAS COUNTY OF HIDALGO CERTIFICATION OF SURVEYOR

I, THE UNDERSIGNED, MANUEL CARRIZALES, A REGISTERED PROFESSIONAL PUBLIC SURVEYOR IN THE STATE OF TEXAS, HEREBY CERTIFY THAT THIS PLAT IS TRUE AND CORRECTLY MADE AND IS PREPARED FROM AN ACTUAL SURVEY ON THE PROPERTY MADE UNDER MY SUPERVISION ON THE GROUND AND THAT THE CORNER MONUMENTS WERE PROPERLY PLACED UNDER MY SUPERVISION AND THAT ALL ASPECTS OF IT ARE IN ACCORDANCE WITH THE CITY OF McALLEN SUBDIVISION ORDINANCE AND ALL STATE STATUTES GOVERNING SURVEYS.

MANUEL CARRIZALES TEXAS R.P.L.S. No. 6388 TEXAS REG. SURVEYING FIRM NO. 101194417

STATE OF TEXAS COUNTY OF HIDALGO CERTIFICATION OF ENGINEER

I, THE UNDERSIGNED, ROBERTO SALINAS, A LICENSED PROFESSIONAL ENGINEER IN THE STATE OF TEXAS, HEREBY CERTIFY THAT PROPER ENGINEERING CONSIDERATION HAS BEEN GIVEN TO THIS PLAT.

ROBERTO SALINAS, PE TEXAS LICENSED PROFESSIONAL ENGINEER No. 122063 TBPES FIRM NO. 21737

OWNER'S ACKNOWLEDGMENT STATE OF TEXAS COUNTY OF HIDALGO

I (WE), THE UNDERSIGNED OWNER OF THE LAND SHOWN ON THIS PLAT, AND DESIGNATED HEREIN AS NORTHGATE ESTATES, DO HEREBY GRANT AN EASEMENT TO THE CITY OF McALLEN AND THOSE WHO MAY NOW OR HEREAFTER HOLD FRANCHISE UNDER SAID CITY, THE USE OF THE STREETS AND EASEMENTS THEREON SHOWN, SURFACE USE OF THE STREETS IS RESTRICTED TO THE EMPLOYEES OR AGENTS OF THE CITY OF McALLEN, EMPLOYEES OF UTILITIES OPERATING UNDER FRANCHISE TO THE CITY OF McALLEN AND RESIDENTS OF THE SUBDIVISION AND THEIR GUESTS, EXCEPT NORTHGATE LANE AND HOBBS DRIVE WHICH ARE FOR PUBLIC USE.

URBAN CITY DEVELOPERS, LLC 4501 EXPY 83, STE 10 McALLEN, TEXAS 78503

JERRY J. BOX P.O. BOX 3376 McALLEN, TEXAS 78501

STATE OF TEXAS COUNTY OF HIDALGO

BEFORE ME, THE UNDERSIGNED AUTHORITY, ON THIS DAY PERSONALLY APPEARED URBAN CITY DEVELOPERS, LLC, KNOWN TO ME TO BE THE PERSON WHOSE NAME IS SUBSCRIBED TO THE FOREGOING INSTRUMENT, AND ACKNOWLEDGED TO ME THAT HE EXECUTED THE SAME FOR THE PURPOSES AND CONSIDERATIONS THEREIN GIVEN UNDER MY HAND AND SEAL OF OFFICE THIS DAY OF _____, 20__.

NOTARY PUBLIC

STATE OF TEXAS COUNTY OF HIDALGO

BEFORE ME, THE UNDERSIGNED AUTHORITY, ON THIS DAY PERSONALLY APPEARED JERRY J. BOX, KNOWN TO ME TO BE THE PERSON WHOSE NAME IS SUBSCRIBED TO THE FOREGOING INSTRUMENT, AND ACKNOWLEDGED TO ME THAT HE EXECUTED THE SAME FOR THE PURPOSES AND CONSIDERATIONS THEREIN GIVEN UNDER MY HAND AND SEAL OF OFFICE THIS DAY OF _____, 20__.

NOTARY PUBLIC

PRINCIPAL CONTACTS:

NAME	ADDRESS	CITY & ZIP	PHONE
OWNER: URBAN CITY DEVELOPERS, LLC	4501 EXPY. 83, STE. 10	McALLEN, TEXAS 78503	956-598-2940
ENGINEER: TURBO ENGINEERS, PLLC	1203 ERIE AVENUE, SUITE F	McALLEN, TX 78501	956-598-2940
SURVEYOR: MANUEL CARRIZALES, R.P.L.S.	4807 GONDOLA AVENUE	EDINBURG, TX 78542	956-567-2167

SHEET 01 OF 01 DATE OF PREPARATION: 3.29.2023 PROJECT NO: 22135

NO.	DATE	DESCRIPTION	BY

Carrizales Land Surveying, LLC
Texas Registered Surveying Firm TBPES FIRM No: 10194417
4807 Gondola Avenue, Edinburg, TX 78542
Office: 956-567-2167
www.cls.land

TURBO ENGINEERS, PLLC
1200 ERIE AVENUE, SUITE F
McALLEN, TEXAS 78501
956.598.2940
roberto@turboengineers.net
TBPES FIRM # 21737

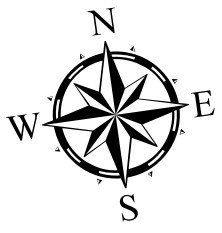

Northgate Estates Subdivision





AGENDA ITEM

2.b.

PUBLIC UTILITY BOARD

DATE SUBMITTED

01/03/2024

MEETING DATE

1/9/2024

1. Agenda Item: Approval of MPU's 1st and Pecan Fire Hydrant Preliminary Reimbursement Certificate

2. Party Making Request: Rafael Balderas Jr.

3. Nature of Request: Request of MPU Board approval of the indicated Preliminary Reimbursement Certificate.

4. Budgeted:

Bid Amount: _____
Under Budget: _____

Budgeted Amount: _____
Over Budget: _____
Amount Remaining: _____

5. Reimbursement: N/A.

6. Routing:
Rafael Balderas Jr. Created/Initiated - 1/3/2024

7. Staff's Recommendation: Staff recommends approval.

8. City Attorney: Approve. IJT

9. MPU General Manager: Approved - MAV

10. Director of Finance for Utilities: Approved - MSC

Memo

TO: Marco A. Vega, P.E., General Manager
J.J. Rodriguez, Asst. General Manager

THRU: Marco Ramirez, P.E., Utility Engineer
Carlos Gonzalez, P.E., Utility Engineer

FROM: Rafael A. Balderas, E.I.T., Asst. to the Utility Engineer

DATE: January 2, 2024

SUBJECT: **1st Street and Pecan Blvd. Fire Hydrant; Consideration & Possible Approval of a Preliminary Reimbursement Certificate**

This item was discussed previously in executive session, with a fire hydrant being required by the McAllen Fire Department due to a development being established in the area of 1st Street and Pecan Boulevard. Back in 1991 the nearby Lot "A" Club Addition No. 2 subdivision went through the subdivision process and was required to install a fire hydrant within the area on the north side of Pecan Boulevard. The then developer ended up installing a fire hydrant on the south side of Pecan Boulevard and escrowed \$5,675 for waterline improvements, which is assumed to include the north side fire hydrant. Given the escrow amount, staff recommends that MPU install the now needed fire hydrant.

In previous years, when MPU installed a fire hydrant, a reimbursement certificate would be created to assess the new developments within the service area.

Below is a breakdown of the possible reimbursement amount:

	Amount
Estimated Waterline & Fire Hydrant Installation	\$20,120
Service Area (Acre)	2.3
Cost per Acre	\$8,747.83

Staff recommends approval.

I'll be available for further discussion/questions at the MPUB meeting.

FABIAN, [REDACTED] INA, INC.

Planning
Attr:
Katrina

PLINIO ([REDACTED]) DR, P.E.
[REDACTED] FABIAN, DESIGNER
C.L. FABIAN, P.E., R.P.S., L.S.L.S., CONSULTANT

320 N. 15th St.
PHONE 682-3414
McALLEN, TEXAS 78501

May 16, 1991

Mr. Gary Wise
Rt. 1 Box 132-W
Pharr, TX 78577

Re: Lot "A" Club Addition #2
McAllen, Texas

Dear Mr. Wise:

The following items are now required to have the subdivision plat for the above referenced project recorded:

- 1) Check to City of McAllen for \$42.50 for recording fee;
- 2) Check to County of Hidalgo for \$25.00 for County application fee;
- 3) Check to City of McAllen for \$5,675.00 for water line improvements (cost estimate attached);
- 4) Tax certificates (not receipts) from:
 - a) County
 - b) City/School
 - c) Hidalgo County Irrigation District #2
- 5) The owner(s) need to come to this office to sign:
 - a) the subdivision plat, and
 - b) the Conveyance of Water Rights.

When Items 1, 2, 3, and 4 are collected, return to us and we will submit them to the City.

RECEIVED JUN 05 1991

Mr. Gary Wise
May 16, 1991
Page 2

It is important for you to know that the City will be requiring an engineered drainage detention plan prior to issuing a building permit. Please let me know if we can be of service to you along that line.

If you have any questions regarding any of these matters, please call or come by.

Sincerely,

FABIAN, NELSON & MEDINA, INC.

Gilberto A. Gracia, P.E.

GAG/jr
Attachment

FABIAN, NELSON AND MEDINA, INC.

Consulting Engineers - Land Surveyors

1st Street Fire Hdyrant Improvement				
Description	Quantity	Unit	Unit Cost	Total Cost
6-inch DR18 Waterline	210	LF	\$ 32.00	\$ 6,720.00
8"x6" Tee w/ 6" Valve	1	EA	\$ 2,000.00	\$ 2,000.00
Fire Hydrant Assembly	1	EA	\$ 5,500.00	\$ 5,500.00
6"x6" Cross	1	EA	\$ 700.00	\$ 700.00
6"x4" Reducer	2	EA	\$ 600.00	\$ 1,200.00
Sidewalk Repair	800	SF	\$ 3.50	\$ 2,800.00
Alley Repair	300	SF	\$ 4.00	\$ 1,200.00
			Total	\$ 20,120.00
			Service Area (Acre)	2.3
			Cost per Acre	\$ 8,747.83

PRELIMINARY REIMBURSEMENT CERTIFICATE

STATE OF TEXAS X
COUNTY OF HIDALGO X

THIS CERTIFICATE, issued by the McAllen Public Utility (MPUB), as authorized by such Board of Trustees, hereinafter called the MPUB to, McAllen Public Utility hereinafter called the DEVELOPER.

1. The DEVELOPER is the developer of the following described property:

Pecan and 1st Street, north of Pecan up to Alley, from 110 Pecan Blvd to 125 Pecan Blvd
(Location)

and proposes to extend a 6-inch waterline for a fire hydrant as shown on a plan designed by
(Service)

McAllen Public Utility, and proposes to construct Utilities Improvements, as approved by the
(Engineering Firm)

MPUB on January 9, 2024 .
(Approval date)

2. The Developer's Cost (\$ 8,747.83 /Ac.), the Pro Rata Share to be reimbursed to the Developer by the Intervening Developers, in accordance with the presently existing MPUB's Reimbursement Policy, is shown on Exhibit "A" attached hereto and made a part hereof.

3. This certificate hereby entitles the holder hereof, being the Developer, to receive reimbursement of the Pro Rata Share from Intervening Developers, after the deduction of the administrative fee by the MPUB, if and when so collected by the MPUB, in accordance with the MPUB's Reimbursement Policy.

4. The installation of the above-described Utilities Improvements will be completed and will be operational, and installed as approved by the CITY.

5. The right to reimbursement is subject to the Reimbursement Policy as established by the McAllen Public Utility Board effective February 2017 or as such policy may hereinafter be amended.

ISSUED in triplicate originals this _____ day of _____, 20__ and

to expire this ____ day of _____, 20__.

CITY OF McAllen BY THE
McALLEN PUBLIC UTILITY

BY: _____
Marco A Vega, P.E.
General Manager, McAllen Public Utility
Post Office Box 220
McAllen, Texas 78505-0220
(956) 681-1630

ATTEST:

Board Secretary

1ST STREET FH IMPROVEMENT

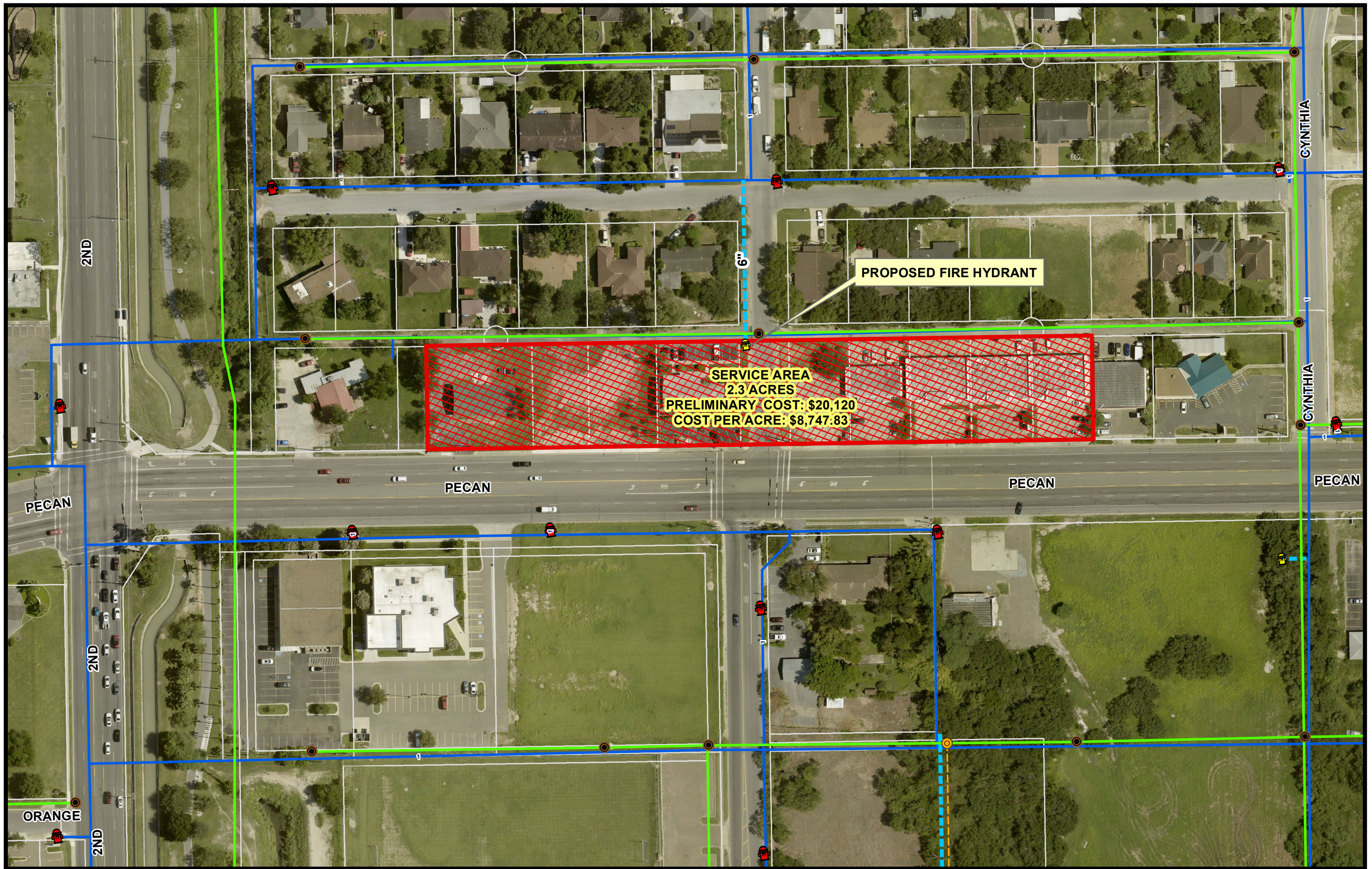

1 inch = 114 feet

SERVICE AREA
2.3 ACRES
PRELIMINARY COST: \$20,120
COST PER ACRE: \$8,747.83

PROPOSED FIRE HYDRANT

- Legend**
-  Existing Manhole
 -  Proposed Manholes
 -  Proposed Fire Hydrant
 -  Existing Fire Hydrants
 -  Existing Wastewater Line
 -  Proposed Wastewater Line
 -  Proposed Water Line
 -  Service Area
 -  Sewer CCN
 -  Lots
 -  Existing Waterline
 -  Proposed Area



AGENDA ITEM 3.a.

PUBLIC UTILITY BOARD

DATE SUBMITTED 01/03/2024

MEETING DATE 1/9/2024

1. Agenda Item: Authorization to Purchase New Current Model MPU Vehicles through Cooperative Contract Pricing– Project No. 11-23-P20-133.

2. Party Making Request:
Elvira Alonzo, Public Works Director

3. Nature of Request:
On November 15, 2023, Public Works through the Purchasing and Contracting Department solicited formal bids for the purchase of Thirty-Three (33) New Current Model Vehicles; Twenty-Three (23) for various City departments and Ten (10) for MPU departments. A total of three (3) vendors responded to our solicitation providing their pricing structure reflecting dealer pricing. Southwest CDJR, from Cleburne, Tx is considered non-responsive due to bid security not being submitted-(Project No. 11-23-P20-133).

4. Budgeted: Yes
Yes
Yes

	\$391,481.00		\$404,000.00
Bid Amount:	\$54,644.00	Budgeted Amount:	\$47,500.00
	<u>\$59,900.00</u>		<u>\$56,500.00</u>
			\$0.00
Under Budget:		Over Budget:	\$7,144.00
			<u>\$3,400.00</u>
			\$0.00
		Amount Remaining:	\$0.00
			<u>\$0.00</u>

5. Reimbursement:

6. Routing:
Javier Zamora Created/Initiated - 1/3/2024
Elvira Alonzo Approved - 1/3/2024
Mark Vega Final Approval - 1/3/2024

7. Staff's Recommendation: Staff recommends award of Purchase Contract(s) to Randall Reeds Prestige Ford of Garland, TX through the Sheriff's Association of Texas Cooperative Contract for Items 4, and 12-13; Silsbee Ford from Silsbee, TX through the TIPS USA Cooperative Contract for Items 7, 15, and 18. The award of contracts is subject to a budget reclassification of funds.

8. City Attorney: Approve. IJT

9. MPU General Manager: Approved - MAV

10. Director of Finance for Utilities: Approved - MSC



Memorandum

To: Mark Vega, P.E., General Manager
From: Elvira I. Alonzo CPM, Director of Public Works
Date: December 28, 2023
Re: **Award of Contracts for the Purchase of New Current Model Vehicles thru Cooperative Pricing – Project No. 11-23-P20-133**

GOAL: The Fleet Operations Department of Public Works requests your authorization to award multiple Purchase Contracts to the lowest responsive responsible bidders meeting the requirements of the specifications and bid solicitation documents. Recommendations are based on a per item basis. Attached for your review, is the bid tabulation depicting the proposed vendor(s) to be contracted with, upon Utility Board approval.

BRIEF EXPLANATION: On November 15, 2023, Public Works through the Purchasing and Contracting Department solicited formal bids for the purchase of Thirty-Three (33) New Current Model Vehicles; Twenty-Three (23) for various City departments and Ten (10) for MPU departments. A total of three (3) vendors responded to our solicitation providing their pricing structure reflecting dealer & COOP purchasing pricing. Southwest CDJR, from Cleburne, Tx is considered non-responsive due to bid security not being submitted.

HISTORY: Historically, the City solicits sealed bids for vehicles that have reached and/or surpassed their life expectancy and have been recommended for replacement. (Please note that all vehicles due for replacement have gone through the justification and budget approval process).

OPTIONS:

1. Award Purchase Contracts as outlined below.
2. The Utility Board may elect to direct staff to reject any or all bids received and to re-advertise this project.



Memorandum

RECOMMENDED VENDOR	ITEM NUMBER	TOTAL CONTRACT AMOUNT
Randall Reeds Prestige Ford from Garland, TX	4, 12-13	\$308,584.00
Silsbee Ford from Silsbee, TX	7, 15, 18	\$197,441.00
	GRAND TOTAL:	\$506,025.00

RECOMMENDATION DETAILS: Staff recommends award of Purchase Contract(s) to Randall Reeds Prestige Ford of Garland, TX through the Sheriff's Association of Texas Cooperative Contract for Items 4, and 12-13; Silsbee Ford from Silsbee, TX through the TIPS USA Cooperative Contract for Items 7, 15, and 18. The award of contracts is subject to a budget reclassification of funds.



BID OPENING: DECEMBER 14, 2023 AT 2:00 PM CST
 LOCATION: CITY HALL CONFERENCE ROOM NO. 2

Yellow Shading depicts Recommended Vendor

PROJECT NO. 11-23-P20-133 PURCHASE OF THIRTY-THREE (33) NEW CURRENT MODEL VEHICLES

NO.	REFERENCE NO.	TYPE	DESCRIPTION	BIDDERS:			SILSBEE FORD SILSBEE, TEXAS			RANDALL REED'S PRESTIGE FORD GARLAND, TEXAS			NON-RESPONSIVE SOUTHWEST CDJR LLC CLEBURNE, TEXAS		
				UOM	QTY		UNIT PRICE	EXT. PRICE	COMMENTS	UNIT PRICE	EXT. PRICE	COMMENTS	UNIT PRICE	EXT. PRICE	COMMENTS
1	071-04	BASE	ITEM NO. 1 - SPECIFICATIONS FOR THE PURCHASE OF ONE (1) NEW CURRENT MODEL 4-DOOR COMPACT SEDAN (HEALTH-1) AS PER SPECIFICATIONS. INDICATE YEAR, MANUFACTURER, MODEL, STANDARD WARRANTY TERMS/CONDITIONS, DELIVERY DAYS AFTER RECEIPT OF ORDER (ARO) IN COMMENT AREA	EA	1			NO BID			NO BID	\$24,588.50	\$24,588.50	2024 NISSAN SENTRA SV, WARRANTY 3 YR/36K BASIC AND 5YR/60K POWERTRAIN. USUALLY WE STOCK THESE AND ARE AVAILABLE FOR DELIVERY WITH 14 DAYS	
2	071-80	BASE	ITEM NO. 2 - SPECIFICATIONS FOR THE PURCHASE OF ONE (1) NEW CURRENT MODEL MID-SIZE 4-DOOR SPORT UTILITY VEHICLES (IT-1) AS PER SPECIFICATIONS. INDICATE YEAR, MANUFACTURER, MODEL, STANDARD WARRANTY TERMS/CONDITIONS, DELIVERY DAYS AFTER RECEIPT OF ORDER (ARO) IN COMMENT AREA	EA	1			NO BID			2024 Ford Explorer	\$28,558.50	\$28,558.50	2024 JEEP COMPASS SPORT 4X4, 3YR/36K BASIC & 5YR/60K POWERTRAIN WARRANTY, CURRENTLY IN STOCK AND AVAILABLE WITH IN 2 WEEKS	
3	072-01	BASE	ITEM NO. 3 - SPECIFICATIONS FOR THE PURCHASE OF TWO (2) NEW CURRENT MODEL ½ TON, REGULAR CAB, P/U TRUCKS (LONG BED, 2WD, GAS) (PARKS-1, RECYCLING-1) AS PER SPECIFICATIONS. INDICATE YEAR, MANUFACTURER, MODEL, STANDARD WARRANTY TERMS/CONDITIONS, DELIVERY DAYS AFTER RECEIPT OF ORDER (ARO) IN COMMENT AREA	EA	2	\$36,470.00	\$72,940.00				2024 Ford F150 regular cab	\$38,473.50	\$76,947.00	2024 CHEV 1500 REG CAB SILVERADO WT 4X2, 3YR/36K BASIC & 5YR/100K POWERTRAIN, ORDER UNIT ALLOW UP TO 300 DAYS	
4	072-01	BASE	ITEM NO. 4 - SPECIFICATIONS FOR THE PURCHASE OF EIGHT (8) NEW CURRENT MODEL ½ TON, EXTENDED CAB P/U TRUCK (SHORT BED, 2WD, GAS) (BUILDING INSPECTIONS-1, ENGINEERING-2, METER READERS-5) AS PER SPECIFICATIONS. INDICATE YEAR, MANUFACTURER, MODEL, STANDARD WARRANTY TERMS/CONDITIONS, DELIVERY DAYS AFTER RECEIPT OF ORDER (ARO) IN COMMENT AREA	EA	8	\$40,585.00	\$324,680.00				2024 Ford F150 Extended cab 2WD	\$49,043.50	\$392,348.00	2024 RAM 1500 BIGHORN QUAD CAB 4X2, 6'4" BED, 3YR/36K BASE & 5YR/100K WARRANTY, ORDER UNIT ALLOW UP TO 300 DAYS	
5	072-01	BASE	ITEM NO. 5 - SPECIFICATIONS FOR THE PURCHASE OF THREE (3) NEW CURRENT MODEL ½ TON, EXTENDED CAB P/U TRUCK (SHORT BED, 4WD, GAS) (ENGINEERING-2, HEALTH-1) AS PER SPECIFICATIONS. INDICATE YEAR, MANUFACTURER, MODEL, STANDARD WARRANTY TERMS/CONDITIONS, DELIVERY DAYS AFTER RECEIPT OF ORDER (ARO) IN COMMENT AREA	EA	3	\$45,600.00	\$136,800.00				2024 Ford F150 Extended Cab 4WD	\$55,131.50	\$165,394.50	2024 RAM 1500 QUAD CAB 4X4, 6' 4" BED, 3YR/36K BASE & 5YR/100K WARRANTY, ORDER UNIT ALLOW UP TO 300 DAYS	
6	072-01	BASE	ITEM NO. 6 - SPECIFICATIONS FOR THE PURCHASE OF THREE (3) NEW CURRENT MODEL ¾ TON EXTENDED CAB & CHASSIS W/ANIMAL CONTROL BODIES (LONG WHEELBASE, 2WD, GAS) (ANIMAL CONTROL-3) AS PER SPECIFICATIONS. INDICATE YEAR, MANUFACTURER, MODEL, STANDARD WARRANTY TERMS/CONDITIONS, DELIVERY DAYS AFTER RECEIPT OF ORDER (ARO) IN COMMENT AREA	EA	3	\$0.00	\$0.00	NO BID			2024 Ford F250 Ext.Cab with Deerskin animal control unit	\$0.00	\$0.00	NO BID - TRUCKS ARE AVAILABLE BUT ANIMAL CONTROL BEDS ARE OVER 1 YEAR TO BE ORDERED AND INSTALLED	
7	072-01	BASE	ITEM NO. 7 - SPECIFICATIONS FOR THE PURCHASE OF ONE (1) NEW CURRENT MODEL ¾ TON, EXTENDED CAB P/U TRUCK (SHORT BED, 2WD, DIESEL) (TRANSMISSION & DISTRIBUTION-1) AS PER SPECIFICATIONS. INDICATE YEAR, MANUFACTURER, MODEL, STANDARD WARRANTY TERMS/CONDITIONS, DELIVERY DAYS AFTER RECEIPT OF ORDER (ARO) IN COMMENT AREA	EA	1	\$51,541.00	\$51,541.00				2024 Ford F250 Ext. Cab 2WD diesel	\$58,335.50	\$58,335.50	2024 RAM 2500 TRADESMAN CREW CAB 6.7LTR DIESEL 4X2 SRW 6/4 BED, 3YR/36K BASE & 5YR 100K POWERTRAIN WARRANTY, ORDER UNIT ALLOW 300 DAYS	

8	072-01	BASE	ITEM NO. 8 – SPECIFICATIONS FOR THE PURCHASE OF ONE (1) NEW CURRENT MODEL ¾ TON, EXTENDED CAB P/U TRUCK (SHORT BED, 4WD, DIESEL) (GRAFFITI-1) AS PER SPECIFICATIONS. INDICATE YEAR, MANUFACTURER, MODEL, STANDARD WARRANTY TERMS/CONDITIONS, DELIVERY DAYS AFTER RECEIPT OF ORDER (ARO) IN COMMENT AREA	EA	1	★	\$57,926.00	\$57,926.00		★	\$58,531.00	\$58,531.00	2024 Ford F250 Ext.cab 4WD diesel	\$61,645.50	\$61,645.50	2024 RAM 2500 TRADESMAN CREW CAB 6.7LTR DIESEL 4X4 SRW 6/4 BED, 3YR/36K BASE & 5YR 100K POWERTRAIN WARRANTY, ORDER UNIT ALLOW 300 DAYS
9	072-01	BASE	ITEM NO. 9 – SPECIFICATIONS FOR THE PURCHASE OF ONE (1) NEW CURRENT MODEL ¾ TON, CREW CAB P/U TRUCK (LONG BED, 2WD, GAS) (PARKS-1) AS PER SPECIFICATIONS. INDICATE YEAR, MANUFACTURER, MODEL, STANDARD WARRANTY TERMS/CONDITIONS, DELIVERY DAYS AFTER RECEIPT OF ORDER (ARO) IN COMMENT AREA	EA	1		\$47,988.00	\$47,988.00		★	\$47,550.00	\$47,550.00	2024 Ford F250 crew cab 2WD	\$49,880.50	\$49,880.50	2024 RAM 2500 CREW CAB 4X2 TRADESMAN 6.4LTR GAS V8 (169 in WB 8 ft 0 in Box)3YR/36K BASE & 5YR 100K POWERTRAIN WARRANTY, ORDER UNIT ALLOW 300 DAYS
10	072-01	BASE	ITEM NO. 10 - SPECIFICATIONS FOR THE PURCHASE OF THREE (3) NEW CURRENT MODEL ¾ TON, CREW CAB P/U TRUCKS (SHORT BED, 4WD, GAS) (TRAFFIC-1, SIDEWALK-1, RESIDENTIAL-1) AS PER SPECIFICATIONS. INDICATE YEAR, MANUFACTURER, MODEL, STANDARD WARRANTY TERMS/CONDITIONS, DELIVERY DAYS AFTER RECEIPT OF ORDER (ARO) IN COMMENT AREA	EA	3		\$49,995.00	\$149,985.00		★	\$49,893.00	\$149,679.00	2024 Ford F250 crew cab 4WD	\$49,990.50	\$149,971.50	2024 RAM 2500 CREW CAB 4X2 TRADESMAN 6.4LTR GAS V8 (149 in WB 6 ft 4 in Box) 3YR/36K BASE & 5YR 100K POWERTRAIN WARRANTY, ORDER UNIT ALLOW 300 DAYS
11	072-01	BASE	ITEM NO. 11 - SPECIFICATIONS FOR THE PURCHASE OF ONE (1) NEW CURRENT MODEL ¾ TON, CREW CAB P/U TRUCK (SHORT BED, 4WD, DIESEL) (GRAFFITI-1) AS PER SPECIFICATIONS. INDICATE YEAR, MANUFACTURER, MODEL, STANDARD WARRANTY TERMS/CONDITIONS, DELIVERY DAYS AFTER RECEIPT OF ORDER (ARO) IN COMMENT AREA	EA	1	★	\$58,974.00	\$58,974.00			\$59,606.00	\$59,606.00	2024 Ford F250 crew cab 4WD diesel	\$62,655.50	\$62,655.50	2024 RAM 2500 CREW CAB 4X4 TRADESMAN SRW (149 in WB 6 ft 4 in BOX, 6.7 DIESEL, 3YR/36K BASE & 5YR 100K POWERTRAIN WARRANTY, ORDER UNIT ALLOW 300 DAYS
12	072-01	BASE	ITEM NO. 12 - SPECIFICATIONS FOR THE PURCHASE OF ONE (1) NEW CURRENT MODEL ¾ TON REGULAR CAB & CHASSIS (GAS, 2WD) W/UTILITY SERVICE BODY (WASTEWATER PLANT-1) AS PER SPECIFICATIONS. INDICATE YEAR, MANUFACTURER, MODEL, STANDARD WARRANTY TERMS/CONDITIONS, DELIVERY DAYS AFTER RECEIPT OF ORDER (ARO) IN COMMENT AREA	EA	1		\$58,500.00	\$58,500.00		★	\$54,644.00	\$54,644.00	2024 Ford F250 Reg.cab with service body	\$65,690.50	\$65,690.50	2024 RAM 2500 REG CAB & CHASSIS TRADESMAN SRW (149 in WB 6 ft 4 in BOX, 6.4 V8 GAS, WITH SERVICE BODY BED, 3YR/36K BASE & 5YR 100K POWERTRAIN WARRANTY, ORDER UNIT ALLOW 300 DAYS
13	072-01	BASE	ITEM NO. 13 - SPECIFICATIONS FOR THE PURCHASE OF ONE (1) NEW CURRENT MODEL ¾ TON CREW CAB & CHASSIS (SRW, DIESEL, 2WD) W/UTILITY SERVICE BODY (TRANSMISSION & DISTRIBUTION-1) AS PER SPECIFICATIONS. INDICATE YEAR, MANUFACTURER, MODEL, STANDARD WARRANTY TERMS/CONDITIONS, DELIVERY DAYS AFTER RECEIPT OF ORDER (ARO) IN COMMENT AREA	EA	1		\$62,500.00	\$62,500.00		★	\$58,550.00	\$58,550.00	2024 Ford F250 Crew.cab with service body	\$67,490.50	\$67,490.50	2024 RAM 2500 TRADESMAN CREW CAB & CHASSIS SRW 4X2 ROYAL TRUCK BODY 6.4 GAS V8 6 SPEED AUTO,3YR/36K BASE & 5YR 100K POWERTRAIN WARRANTY, ORDER UNIT ALLOW 300 DAYS
14	072-01	BASE	ITEM NO. 14 - SPECIFICATIONS FOR THE PURCHASE OF ONE (1) NEW CURRENT MODEL 1 TON EXTENDED LENGTH, 15-PASSENGER VAN (2WD, GAS) (RECREATION-1) AS PER SPECIFICATIONS. INDICATE YEAR, MANUFACTURER, MODEL, STANDARD WARRANTY TERMS/CONDITIONS, DELIVERY DAYS AFTER RECEIPT OF ORDER (ARO) IN COMMENT AREA	EA	1		\$0.00	\$0.00	NO BID	★	\$53,144.00	\$53,144.00	2024 Ford Transit T350 15 passenger	\$0.00	\$0.00	NO BID
15	072-01	BASE	ITEM NO. 15 - SPECIFICATIONS FOR THE PURCHASE OF ONE (1) NEW CURRENT MODEL 1-TON, CREW CAB P/U TRUCK (SHORT BED, 4WD, DIESEL) (WASTEWATER ADMIN-1) AS PER SPECIFICATIONS. INDICATE YEAR, MANUFACTURER, MODEL, STANDARD WARRANTY TERMS/CONDITIONS, DELIVERY DAYS AFTER RECEIPT OF ORDER (ARO) IN COMMENT AREA	EA	1	★	\$59,900.00	\$59,900.00			\$60,744.00	\$60,744.00	2024 Ford F350 Crew cab 4WD diesel	\$63,749.50	\$63,749.50	2024 RAM 3500 CREW CAB 4X4 TRADESMAN (149 in WB 6 ft 4 in Box) (149 in WB 6 ft 4 in Box) 6.7L I6 Cummins Turbo Diesel Engine 6 SPEED TRANSMISSION, 3YR/36K BASE & 5YR 100K POWERTRAIN WARRANTY, ORDER UNIT ALLOW 300 DAYS
16	072-01	BASE	ITEM NO. 16 - SPECIFICATIONS FOR THE PURCHASE OF ONE (1) NEW CURRENT MODEL 1- TON CREW CAB & CHASSIS (DRW, GAS, 2WD) W/UTILITY SERVICE BODY (PARKS-1) AS PER SPECIFICATIONS. INDICATE YEAR, MANUFACTURER, MODEL, STANDARD WARRANTY TERMS/CONDITIONS, DELIVERY DAYS AFTER RECEIPT OF ORDER (ARO) IN COMMENT AREA	EA	1		\$59,500.00	\$59,500.00		★	\$52,266.00	\$52,266.00	2024 Ford F350 crew cab DRW 4WD	\$60,249.50	\$60,249.50	2024 RAM 3500 CREW CAB CHASSIS 4X2 3500 CREW CAB & CHASSIS 2WHD (172.4 in WB - CA of 60 in)NO BED - ITS A CREW CAB CH 6.4 V8 GAS 6 SPEED AUTO,3YR/36K BASE & 5YR 100K POWERTRAIN WARRANTY, ORDER UNIT ALLOW 300 DAYS

17	072-01	BASE	ITEM NO. 17 - SPECIFICATIONS FOR THE PURCHASE OF ONE (1) NEW CURRENT MODEL 1-TON EXTENDED CAB & CHASSIS (DRW, 2WD, DIESEL) W/FLATBED BODY (DRAINAGE-1) AS PER SPECIFICATIONS. INDICATE YEAR, MANUFACTURER, MODEL, STANDARD WARRANTY TERMS/CONDITIONS, DELIVERY DAYS AFTER RECEIPT OF ORDER (ARO) IN COMMENT AREA	EA	1	\$64,900.00	\$64,900.00	\$64,740.00	\$64,740.00	2024 Ford F350 Ext.cab 2WD GAS ONLY AVAILABLE . if need regular cab diesel with flat bed 84CA quote :72410	\$0.00	\$0.00	NO BID
18	072-05	BASE	ITEM NO. 18 - SPECIFICATIONS FOR THE PURCHASE OF ONE (1) NEW CURRENT MODEL 19,000 GVW CREW CAB & CHASSIS W/3-4 CUBIC YARD DUMP BODY (DRW, 2WD, DIESEL) (TRANSMISSION & DISTRIBUTION-1) AS PER SPECIFICATIONS. INDICATE YEAR, MANUFACTURER, MODEL, STANDARD WARRANTY TERMS/CONDITIONS, DELIVERY DAYS AFTER RECEIPT OF ORDER (ARO) IN COMMENT AREA	EA	1	\$86,000.00	\$86,000.00	\$90,880.00	\$90,880.00	2024 Ford F550 crew cab with dump 3-4 yard	\$0.00	\$0.00	NO BID
19	072-05	BASE	ITEM NO. 19 - SPECIFICATIONS FOR THE PURCHASE OF ONE (1) NEW CURRENT MODEL 19,000 GVW REGULAR CAB & CHASSIS W/CM AERIAL DEVICE BODY (DRW, 2WD, DIESEL) (TRAFFIC-1) AS PER SPECIFICATIONS. INDICATE YEAR, MANUFACTURER, MODEL, STANDARD WARRANTY TERMS/CONDITIONS, DELIVERY DAYS AFTER RECEIPT OF ORDER (ARO) IN COMMENT AREA	EA	1						\$0.00	\$0.00	NO BID
GRAND TOTAL:						\$1,292,134.00	\$1,650,496.00				\$0.00	\$0.00	\$1,327,505.00
SPECIFICATIONS (PAGES 21-87 INCLUDING SIGNATURE PAGES):						SUBMITTED		SUBMITTED		SUBMITTED			
BID & SUPPLEMENTAL FORMS (PAGES 88-94):						SUBMITTED		SUBMITTED		SUBMITTED			
TIMELINE (PAGES 7-8):						SUBMITTED		SUBMITTED		SUBMITTED			
VEHICLE WARRANTY INFORMATION:						SUBMITTED		SUBMITTED		SUBMITTED			
COOPERATIVE NAME, CONTRCAT NO & EXPIRATION DATE:						TIPS USA, 210907 AUTOMOBILES		SHERIFF'S ASSOCIATION OF TEXAS		N/A (NO BID BOND SUBMITTED)			
IRS FORM W9:						SUBMITTED		SUBMITTED		SUBMITTED			



	AGENDA ITEM	<u>5.a.</u>
PUBLIC UTILITY BOARD	DATE SUBMITTED	01/03/2024
	MEETING DATE	1/9/2024

1. Agenda Item: Consultation with City Attorney regarding pending litigation (Section 551.071, T.G.C)

2. Party Making Request:

3. Nature of Request:

4. Budgeted:

Bid Amount:	_____	Budgeted Amount:	_____
Under Budget:	_____	Over Budget:	_____
		Amount Remaining:	_____

5. Reimbursement:

6. Routing:
Savannah Arredondo Created/Initiated - 1/3/2024

7. Staff's Recommendation:

8. City Attorney: None. IJT

9. MPU General Manager: N/A - MAV

10. Director of Finance for Utilities: N/A - MSC